

TEST PROCEDURE COVER SHEET

NEW XXXX UPDATE



MFG ID NUMBER 23810 ISSUE 01 PAGE 1 OF 50

PRODUCT NAME iSBC-216A PWA NUMBER 133434-xxx

PROCEDURE TITLE: iSBC216A STBL Test Instruction

ORIGINATOR: Jerrie Coffman DV1-418 x4722

(PRINT NAME HERE) _____

PTE: Doug Guillot 04/15/85

QE: _____

PTE SIGNATURE REQUIRED ON RELEASES TO PRODUCTION.

QE SIGNATURE REQUIRED ON RELEASES TO IQC.

NOTE

THIS INSTRUCTION IS NOT IN THE CORRECT FORMAT FOR CURRENT MID RELEASE. PLEASE UPDATE ON NEXT ECO

1. AUTHORITY FOR CHANGE CONTROL IS THE RESPONSIBLE TEST/MANUFACTURING PRODUCT ENGINEERING SUPERVISOR.
2. (C) INTEL CORPORATION 1978. ALL RIGHTS RESERVED. NO PART OF THIS PUBLICATION MAY BE REPRODUCED, TRANSMITTED, TRANSCRIBED, STORED IN A RETRIEVAL SYSTEM, OR TRANSLATED INTO ANY LANGUAGE OR COMPUTER LANGUAGE, IN ANY FORM OR BY ANY MEANS, ELECTRONIC, MECHANICAL, MAGNETIC, OPTICAL, CHEMICAL, MANUAL, OR OTHERWISE, WITHOUT THE PRIOR WRITTEN PERMISSION OF INTEL CORPORATION, 3065 BOWERS AVENUE, SANTA CLARA, CALIFORNIA 95051, USA.

APR 15 1985



COPY
AUG 28 1986
SANTA CLARA, CALIFORNIA

TABLE OF CONTENTS

1. Purpose.....	2
2. Scope.....	2
3. Reference Documents.....	2
4. Definitions.....	3
5. Test Equipment.....	4
6. Safety.....	5
7. Procedure.....	5
7.1. Test Set Up.....	5
7.1.1. Board Set Up.....	5
7.1.2. System Set Up.....	8
7.2. Environmental Conditions.....	9
7.2.1. STBL.....	9
7.2.2. Reliability.....	9
7.3. Pre-test Checks.....	9
7.4. System Test Board Level.....	10
7.5. Reliability.....	15
8. Preventive Maintenance.....	17
8.1. Daily Check.....	17
8.2. Cleaning.....	17
8.2.1. Head Cleaning.....	17
8.2.2. Other Cleaning.....	17
8.3. Routine Adjustment.....	17
8.4. Lubrication.....	18
8.5. Head Wear.....	18
8.6. Periodic Inspection.....	18
9. iSBC-216A Board Diagnostics.....	19
9.1. Level 1 System Monitor.....	19
9.2. Level 2 GPCP.....	22
9.3. Level 3 MELTT1.....	22
9.4. Level 4 MELTT2.....	23
10. Drive Diagnostics and Adjustments.....	31
10.1. Power.....	31
10.2. Online Diagnostics.....	32
10.3. Offline Diagnostics.....	32
10.3.1. Continuous Load.....	34
10.3.2. Ramp Adjust.....	34
10.3.3. Tape Speed Adjust.....	34
10.3.4. Write File Mark Continuous.....	34
10.3.5. Read Continuous.....	34
10.3.6. Write Continuous.....	34
10.3.7. Controller SA.....	35

10.3.8. Read Sequencer SA.....	35
10.3.9. Write Sequencer SA.....	35
10.3.10. Continuous Self Test.....	35
10.3.11. Short and Long Loads.....	35
11. Appendix.....	36
11.1. Monitor Command List.....	36
11.2. GPCP Command List.....	37
11.3. List of Available Tests.....	38
11.4. STBL Test Flowchart.....	39
11.5. Description of Tests.....	41
11.6. Memory Map.....	49
11.7. Benchmark Report.....	50

1. Purpose

The purpose of this document is to provide the user with the required information to perform STBL and Reliability testing.

2. Scope

This document provides the guidelines for performing STBL and Reliability testing for the iSBC-216A 1/4 inch start/stop tape drive controller board.

3. Reference Documents

O.M.S. Test Engineering Source Document	T.E. 1104 Rev. D
--	------------------

O.M.S. Test Engineering General Purpose Test Fixture Source Document	T.E. 1401 Rev. A
---	------------------

iSBC-216A Internal Product Specification	#133468
iSBC-216A External Product Specification	#133467
iSBC-216A Schematic Diagram	#133151
iSBC-216A Test Specification	#XXXX
iSBC-216A Magnetic Tape Subsystem Diagnostic Specification	#133508
Drive and Power Supply Box Build Documentation	#XXXX
iSBC-216A Test Software Listing	#XXXX

4. Definitions

- GPTF - An acronym for the General Purpose Test Fixture. This test fixture was developed by Intel Oregon, Test Engineering and was designed specifically for use with Multibus compatible iSBC boards.
- GPCP - An acronym for the General Purpose Control Program which resides in PROMS on the host 86/12 (A) single board microcomputer in the GPTF.
- MELTT - An acronym for the Monitor/English Language Test Translator program which resides in TUF 216A PROMS on the two 464 boards in the GPTF.
- UUT - An acronym for Unit Under Test.
- IOPB - An acronym for the I/O Parameter Block.
- CIB - An acronym for the Controller Invocation Block.
- IBG - An acronym for Interblock Gap which is a separation field of 1.2 inches of "blank" tape between data records.
- FM - An acronym for File Mark which is a special record consisting of a unique data pattern. It is impossible for the user to ever inadvertently reproduce this pattern.
- BOT - An acronym for Beginning of Tape.
- EOT - An acronym for End of Tape.
- LLP - An acronym for Logical Load Point.
- LEOT - An acronym for Logical End of Tape.
- Record- A variable number of data bytes (16K maximum) preceded and terminated by IBG's on the tape.
- File - A group of records terminated by a FM.

5. Test Equipment

The following is a list of the necessary test equipment to perform STBL and Reliability tests on the iSBC-216A 1/4 inch start/stop tape drive controller:

GPTF (Hot Box)
CRT (Zentec)
RS232 CRT Cable (P/N 4000417-01)
25 pin flat ribbon cable (P/N 4000677-02)
Kennedy 1/4 inch start/stop tape drive model 6455 and
Power Supply bay
Tape Data Cartridge (3M DC300A or DC300XL type isoelastic or equivalent)

Multimeter

Oscilloscope

Gold iSBC-216A Controller Board (P/N 133152-004 Rev DR)

32K RAM Board (P/N 05-0632-004)

2 464 PROM Boards (P/N 1002046-01 Rev F)

Test Firmware:

2716 labeled	TE	1401	GPCP	A28
2716 labeled	TE	1401	MON	A29
2716 labeled	TE	1401	GPCP	A46
2716 labeled	TE	1401	MON	A47

2732 labeled	TUF	1.1	216A	1	A1
2732 labeled	TUF	1.1	216A	1	A2
2732 labeled	TUF	1.1	216A	1	A3
2732 labeled	TUF	1.1	216A	1	A4
2732 labeled	TUF	1.1	216A	1	A11
2732 labeled	TUF	1.1	216A	1	A12
2732 labeled	TUF	1.1	216A	1	A13
2732 labeled	TUF	1.1	216A	1	A14
2732 labeled	TUF	1.1	216A	1	A18
2732 labeled	TUF	1.1	216A	1	A19
2732 labeled	TUF	1.1	216A	1	A20
2732 labeled	TUF	1.1	216A	1	A21
2732 labeled	TUF	1.1	216A	1	A27
2732 labeled	TUF	1.1	216A	1	A28
2732 labeled	TUF	1.1	216A	2	A 1
2732 labeled	TUF	1.1	216A	2	A 2
2732 labeled	TUF	1.1	216A	2	A11
2732 labeled	TUF	1.1	216A	2	A12
2732 labeled	TUF	1.1	216A	2	A18
2732 labeled	TUF	1.1	216A	2	A19
2732 labeled	TUF	1.1	216A	2	A25
2732 labeled	TUF	1.1	216A	2	A26

> Not there

6. Safety

Typically, common sense is all that is required to prevent most personal injury. Unfortunately, common sense is very uncommon which makes it necessary to have a safety section in this procedure. The single most important thing to remember when working with a Hot Box is that it is hot. The caution stickers on the side of the hot box indicate this and unless you look at the thermometer on the front of the box there is no difference between the appearance of a cold hot box and one that is not.

7. Procedure

7.1. Test Set Up

7.1.1. Board Set Up

A. 86/12(A) Host Microcomputer

1. Set switch 1 to the following:

	ON	OFF
SW1	1,2,5,8	3,4,6,7

2. Install the following:

Jumper: 5-6, 92-93, 103-104, 105-106, 127-128

3. Insure that the following jumpers are installed:

Jumper:	7- 8	26-27	59-60
	7-10	26-91	72-80
	13-14	30-31	79-83
	15-16	32-33	87-89
	15-25	39-40	94-96
	17-18	42-43	97-98
	19-20	54-55	129-130
	24-35	56-57	143-144
			151-152

4. Install the four(4) PROMS listed in 4.0 (test firmware) labeled with the key words MON and GPCP. (PROM location is indicated on the label).

B. 464 PROM Board's 1 & 2

1. Set the switches to the following:

	ON	OFF
S1	1-4	5-8
S2		1-8
S3	5-8	1-4
S4		1-8
S5		1-8
S6	1-4	5-8
S7		1-8
S8	5-8	1-4
S9	1-4,6-8	5
S10	1,2,4	3
S11	For PROM board number	
	1 (20000H)	
	1,2,4,6,8	3,5-7,9,10
	For PROM board number	
	2 (30000H)	
	1,2,8	3-7,9,10
S12	2,4,6,8	1,3,5,7

2. Install jumper packs in the indicated sockets

	jumpered	open
W1	X	
W2	X	
W3		X
W4		X
W5		X
W6	X	
W7		X

3. Install the twenty-two (22) proms called out in 4.0 (test firmware labeled with the key word TUF). The prefix of "1" before the "A" indicates PROM board number 1 (20000H), "2" indicates PROM board number 2 (30000H).

C. 32K RAM Board

1. Install the following:

Jumper:	E1-E 9	E29-E30
	E4-E16	E50-E51
	E5-E22	
	E7-E17	
	E8-E18	

D. Kluge Board

1. Set Switch 1 to the following:

	ON	OFF
SW1	6	1-5,7,8

E. UUT (iSBC-216A 1/4 start/stop tape drive controller)

The iSBC-216A should be strapped in such a manner as to create CBA 133434 as indicated on ECO 21-54024. One exception to this may be the interrupt level of the board. Normally the interrupt level is set to match the system application in accordance with a configuration table and notes on the assembly drawing. However, for STBL and Reliability testing, the iSBC-216A board should be strapped for interrupt one, E29 - E33.



7.1.2. System Set Up

- A. Insure that the power switches to the hot box, tape drive and power supply bay, and CRT are in the off position.
- B. Plug the power cords of the hot box, tape drive and power supply bay, and CRT into 110 VAC, 60Hz outlets.
- C. Install the 464 PROM boards into slots J4 and J5 of the back card cage of the Hot box.
- D. Install the host 86/12 (A) board in slot J2 of the back card cage.
- E. Install the Kluge card in slot J5 of the middle card cage.
- F. Install the 32K RAM board in slot J4 of the middle card cage.
- G. Install the UUT in slot J2 of the front card cage. (Note: The UUT must be in a slot accompanied with a P2 edge connector.)
- H. Connect the 34 pin flat ribbon cable originating from the back of the tape drive and power supply bay to J1 of the UUT.
- I. Connect the test clip labled MPRO inside the hot box to pin E16 on the UUT. In order to determine the reliability of the wire wrap jumper on this pin, the MPRO test clip should be attached to the stake pin only and should not touch the wire wrap jumper directly.
- J. Connect the 25 pin flat ribbon cable to the RS232 CRT cable and connect the cables to J2 of the 86/12 (A) board and the CRT I/O port.

BS

7.2. Environmental Conditions

7.2.1. STBL

For STBL testing, all tests will be run according to section 5.4 with the following environmental conditions:

1. Voltage — all voltages set to nominal.
2. Temperature — 25 degrees centigrade \pm 2 degrees.

7.2.2. Reliability

For reliability testing, all tests will be run according to section 5.5 with the following environmental conditions:

1. Voltage — all voltages margined at \pm 10%.
2. Temperature — 55 degrees centigrade \pm 2 degrees.

7.3. Pre-test Checks

Voltage --

Insure that the knob on the voltage margin box is set to nominal.

Temperature --

- A. Power up the hot box and CRT.
- B. Depress the set button on the temperature gauge and verify that the temperature is set at 55 degrees C.
- C. If the temperature is not set properly, then adjust the temperature setting by inserting a precision screw river into the adj hole on the temperature gauge and turning the screw driver while holding the set pt button in until the desired temperature setting is achieved.
- D. Power down the hot box and CRT.

Jumpers On UUT --

Insure that the test clip labled MPRO inside the hot box is connected to stake pin E16 on the UUT and is not in direct contact with the wire wrap jumper on this pin.

Insure that a jumper is present between terminals E29 and E33.

System —

If the test system has previously been proven to be functional then go to section 5.4 and begin testing boards.

If the test system has not been proven to be functional, then follow the steps below:

- A. Install a gold ISBC-216A board with the jumper configuration called out in section 5.1.1 E into slot J2 of the Hot box's front card cage.
- B. Install the cabling and test jumpers to the 216A board and the system as described in sections H and I.
- C. Go to section 7.4 and perform steps 1 to 21.
- D. If no errors have occurred then the system is functional and board testing can begin. Repeat section 7.1.2, G thru I, then go to section 7.4 to begin testing boards.
- E. If errors have occurred, then carefully, clean the tape head on the drive according to section 8.2.1 and perform the offline diagnostic checks on the tape drive according to section 10.3.
- F. Repeat step C.
- G. If no errors have occurred, then the system is now functional. Repeat section 7.1.2, G thru I, then go to section 7.4 to begin testing boards.
- H. If errors have occurred, then refer the problem to the maintenance and calibration group in DV-1, PSSM, Test Engineering.

7.4. System Test Board Level

1. Turn power on to the CRT.
2. Turn power on to the hot box.
3. Turn power on to the tape drive and power supply bay.
The display:

| ISBC 86/12 Monitor, 6/14 |

should appear on the screen.

4. Insert a tape data cartridge into the drive. The length of tape in the data cartridge should be three hundred feet (Scotch DC300XL or equivalent).
5. Depress the reset switch on the hot box to insure that the boards are properly reset. Wait for the LED indicator on the UUT to go out before continuing. If the LED does not go out within 10 (ten) seconds, an error was detected during the on board power up diagnostics execution. Continue with the next step for more information.
6. Type : G<CR>
The display:

```
-----  
|          CMO iSBC-216A EPROM based system test, V1.1          |  
|          *                                                    |  
|-----|
```

should appear on the screen.

7. Type : 1<CR>
The display:

```
-----  
|          Summary has been cleared          |  
|          Now reading Controller Command Port          |  
|          Returned status indicates:          |  
|                                     00H --- No Error |  
|          Enter the desired CRT output mode          |  
|          <0 = minimum output, 1 = maximum output> |  
|          Default = minimum output          |  
|-----|
```

should appear on the screen.

8. Type : <CR>
The display:

```
-----  
|          Do you want testing to stop if a failure |  
|          occurs <1 = yes, 0 = no> ?          |  
|          Default = yes          |  
|-----|
```

should appear on the screen.

9. Type : <CR>
The display:

```
-----  
| How do you want the tests run <0 =  
| Automatically, 1 = By request> ?  
| Default = Automatically  
-----
```

should appear on the screen.

10. Type : <CR>
The display:

```
-----  
| Do you want the loop test function enabled  
| <0 = yes, 1 = no> ?  
| Default = no  
-----
```

should appear on the screen.

11. Type : <CR>
To run all the tests once.

12. When tests are complete the display:

```
-----  
| Enter the desired CRT output mode  
| <0 = minimum output, 1 = maximum output> ?  
| Default = minimum output  
-----
```

should appear on the screen.

13. Type : <CR>
The display:

```
-----  
| Do you want testing to stop if a failure  
| occurs <0 = yes, 1 = no> ?  
| Default = yes  
-----
```

should appear on the screen.

14. Type : <CR>
The display:

```
-----  
| How do you want the tests run  
| <0 = Automatically, 1 = By request> ?  
| Default = Automatically  
-----
```

should appear on the screen.

15. Type : 1<CR>
The display:

```
-----  
| Initial board test procedure:  
|  
| "Menu" provides a command summary for  
| reference  
| "Test Menu" provides a list of the available  
| iSBC-216A functionality tests.  
|  
| Note that "Reset Unit" automatically  
| performs "Initialize Unit" when called.  
|  
| Pressing the "escape" Key (ESC) will allow  
| you to change the options which have been  
| selected.  
|  
| Function or Exit ?  
-----
```

should appear on the screen.

16. Type : Cartridge Interrupt<CR>
After the tape is loaded (about 20 seconds) the display:

```
-----  
| Cartridge Interrupt Test  
| Please remove the data cartridge from the  
| tape drive and type a carriage return.  
-----
```

should appear on the screen.

17. Pull the tape data cartridge from the tape drive.

18. Type : <CR>
The display:

```
-----  
| Thank You  
| Please insert the data cartridge into the  
| tape drive and type a carriage return.  
|  
-----
```

should appear on the screen.

19. Insert the data cartridge into the tape drive.
20. Type : <CR>
The display:

```
-----  
| Thank You  
| "Passed"  
|  
| Function or Exit ?  
|  
-----
```

should appear on the screen.

21. Type : Summary<CR>
to display the error summary status for the UUT.
22. If the UUT passes (no failures) then the STBL test is complete. Go to section 7.5 to perform the reliability test.
23. If the UUT fails (one or more failures) then refer to section 7 on ISBC-216A board diagnostics to isolate the problem.

7.5. Reliability

1. Turn on the heat switch on the Hot Box and allow the temperature to rise to its preset value of 55 degrees centigrade. Insure that all access doors on the tester are closed.
2. Turn the knob on the voltage margin box to +10 %.
3. Press the Escape key on the CRT.
The display:

```
-----  
| Enter the desired CRT output mode |  
| <0 = minimum output, 1 = maximum output> ? |  
| Default = minimum output |  
-----
```

should appear on the screen.

4. Repeat steps 8 thru 21 of section 7.4.
5. If the UUT passes (no failures) then go to step 7 and perform the -10% voltage margining tests.
6. If the UUT fails (one or more failures) then refer to section 9 on iSBC-216A board diagnostics to isolate the problem.
7. Turn the knob on the voltage margin box to -10 %.
8. Press the Escape key on the CRT.
The display:

```
-----  
| Enter the desired CRT output mode |  
| <0 = minimum output, 1 = maximum output> ? |  
| Default = minimum output |  
-----
```

should appear on the screen.

9. Repeat step 4 above.
10. If the UUT fails then go to step 6 above.
11. If the UUT passes (no errors) then the iSBC-216A reliability test is complete. Turn the knob on the voltage margin box back to nominal. Turn off the heat switch on the front of the Hot Box. Remove the tape data cartridge from the drive. Power down the system, remove the MPRO test clip, and disconnect the tape drive interface cable. Remove the UUT from the system. Looks like our work is done here, Tonto.

8. Preventive Maintenance

To assure continuing trouble-free operation a preventive maintenance schedule should be kept. The items involved are few and simple but very important to proper tape transport operation. The frequency of performance will vary somewhat with the environment and degree of use of the transport, so a rigid schedule applying to all machines is difficult to define.

8.1. Daily Check

Visually check the machine for cleanliness and obvious misadjustment. If items in the tape path show evidence of dirt or oxide accumulation, clean thoroughly.

8.2. Cleaning

All items in the tape path must be kept scrupulously clean. This is particularly true of the head. When cleaning heads, it is important to be thorough yet gentle and to avoid certain dangerous practices.

8.2.1. Head Cleaning

Oxide or dirt accumulations on the head surfaces are removed using a mild organic solvent and a swab. Q tips are convenient but must be used with caution. Be sure the wooden portion does not contact the head surfaces.

An ideal solvent is 1.1.1 trichloroethane contained in the Kennedy K21 maintenance kit. However, other solvents such as isopropyl alcohol will do.

- DO NOT USE - acetone or lacquer thinner
- aerosol spray cans
- rubbing alcohol

Do not use an excess of any solvent, and be extremely careful not to allow solvent to penetrate the ball bearings of the capstan motor, since it will destroy their lubrication.

8.2.2. Other Cleaning

Use a vacuum cleaner to remove accumulations of dust. Compressed air may be used if caution is exercised to avoid blowing dirt into the bearings.

8.3. Routine Adjustment

There are no routine adjustments. Need for adjustment becomes manifest when malfunction occurs. Under normal circumstances adjustment will be more likely to cause trouble than to prevent it.

8.4. Lubrication

No bearing lubrication is required. All bearings are lubricated for life and introduction of oil may destroy their lubrication.

8.5. Head Wear

Head wear is generally signaled by an increase in error rate. Confirmation is a sizable increase in the output voltage from the read head as measured at the read preamplifier. When the head becomes worn it must be replaced. Worn heads usually can be resurfaced at least once if returned to the factory. This is more economical than replacement with a new head.

8.6. Periodic Inspection

Every two months, it is advisable to make a more thorough check of machine operating parameters to insure that no progressive degradation goes unnoticed. The recommended sequence for checks is given in section 10.3.

9. iSBC-216A Board Diagnostics

In order to effectively troubleshoot the iSBC-216A board at STBL level, the following documents should be in hand:

iSBC-216A Internal Product Specification	#133468
iSBC-216A External Product Specification	#133467
iSBC-216A Schematic Diagram	#133151

With the above information and the diagnostic routines presented below, troubleshooting a fault can be attempted. Note that this section is not a fixed routine to be followed when diagnosing a fault by any means. It simply lists and describes some of the options available to the technician. The technician is not limited to the information presented here, but is free to use any other means possible to find and correct a problem. Basic troubleshooting techniques such as close inspection of the defective board, open/shorts testing, etc. should be employed before turning to this section.

Four command sets are available in the iSBC-216A STBL test firmware. They are:

System Monitor
GPCP
MELTT 1
MELTT 2

These four command sets interact with each other to form the total test software package. It should be noted that changing a parameter in one of the command sets can affect one or more of the other command sets. This can be useful and will become apparent as more information is presented. Each command set has its own use and provides its own level and form of information.

9.1. Level 1 System Monitor

The system monitor, even though it is the lowest and most basic level, is a very powerful tool. In fact, it is possible to perform the functions of all the other levels through the system monitor, crude though it may be. A summary of the monitor command list and syntax is provided in the Appendix. The use of the system monitor is usually limited to the memory display routines and the port I/O functions.

The memory display routine is useful when examining the data structures of the iSBC-216A board. These structures can be downloaded into the system memory from the 216A using the controller diagnostic command (MELTT 2) and downloading the entire status structure table. Enter the system monitor by typing Exit <CR> to leave MELTT 2 and M <CR> to leave the GPCP. Use the display command to examine the status structure contents. The starting address of the status structure is always 1000:439F.

The data may be interpreted by using the iSBC-216A External Product specification in conjunction with the chart listed below. The significance of this data is that it shows exactly what the 216A status is and the data and addresses used by the board internal to the system. This provides a window for the operator to look into the board and see what it "thinks".

Status Structure Table

```

STATUS STRUCTURE STRUC
  HARD      DW ?           ; HARD ERROR STATUS DW
  SOFT      DW ?           ; SOFT ERROR STATUS DW
  DESIRED_TRACK DB ?       ; SPECIFIED TRACK
  ACTUAL_TRACK DB ?       ; FOUND TRACK
  NUMBER_RECORDS_RETRIED DW ? ; NUMBER OF RECORDS RETRIED PER IOPB
  NUMBER_RETRIES DB ?     ; NUMBER OF READ/WRITE RETRIES
  SEQUENCER_PORT_ERRORS DW ? ; NUMBER OF READ/WRITE ERRORS
  ; DETECTED BY SEQUENCER PORT
  STATUS_PORT_ERRORS DW ? ; NUMBER OF READ/WRITE ERRORS
  ; DETECTED BY STATUS PORT
  KENNEDY_DATA_ERRORS DW ? ; NUMBER OF READ/WRITE ERRORS
  ; DETECTED BY KENNEDY DATA ERROR
  ; IN STATUS BYTE
  STATE_NUM DB ?         ; STATE WHERE EXECUTION WILL BEGIN
  ; ON NEXT PASS
  COMMAND   DW ?         ; DRIVE COMMAND WORD
  STAT     DB ?         ; MIRROR OF IOPB_LOCAL.OP STATUS
  ; FOR OPERATION COMPLETE GOOD/BAD
  UNIT_STAT DW ?         ; MIRROR OF IOPB_LOCAL.UNIT STATUS
  ACT_CNT   DD ?         ; MIRROR OF IOPB_LOCAL.ACTUAL_COUNT
  STAT_FUNCTION DB ?     ; MIRROR OF IOPB_LOCAL.FUNCTION
  SEQUENCER_STATE DB ?   ; STATE OF ISBC 216 SEQUENCER
  ACT_THIS_IO DW ?      ; NUMBER OF BYTES TRANSFERED BY
  ; INDIVIDUAL READ OR WRITE NOT
  ; ACCUMULATIVE
  COMMAND_PORT_VALUE DB ? ; KENNEDY DRIVE COMMAND BYTE
  CONTROL_PORT_VALUE DB ? ; 216A BOARD CONTROL BYTE
  SEQUENCER_PORT_VALUE DB ? ; COPY OF SEQUENCER PORT
  STATUS_PORT_VALUE DB ? ; COPY OF STATUS PORT
  DMA_ADDR_PORT_VALUE DW ? ; COPY OF 2940 ADDRESS PORTS
  DMA_COUNT_PORT_VALUE DW ? ; COPY OF 2940 COUNT PORTS
  ; IOPB OPERATIONS
  COMMAND_ERRORS DW ?   ; NUMBER OF IOPB COMMAND ERRORS
  BUFFER_COMPARE_FLAG DB ? ; SET FOR READ AND COMPARE
  ; RECORD/FILE
  DRIVE DB 6 DUP (?)    ; DRIVE STATUS DB
  ; SUMMARY, POSITION, 24 BLANK
  EXIT_FLAG DB ?       ; 00=DON'T EXIT IOPB, FF=EXIT IOPB
  IO_TYPE DB ?        ; USED BY READ/WRITE FOR OVERLAPPED
  FILLER2 DB 56 DUP (?) ; INTERNAL VARIABLES--SEE VARI_LOCAL_
  ; STRUCTURE
STATUS_STRUCTURE ENDS

```

The I/O functions of the monitor can be used to reset the 216A (hardware or software) initialize the controller, etc. according to the iSBC-216A External product specification. This method can be used to "hand operate" the 216A and walk it through some of its basic functions.

9.2. Level 2 GPCP

The GPCP is the next higher level of the STBL system and is called from the monitor by typing G <CR>. A summary of the GPCP command list is provided in the appendix. This command list is not complete; however, the functions that were omitted were either not supported or of no consequence. For this reason, the GPCP is of little use in this application other than for calling up the next level of the STBL software and exiting back into the monitor. The GPCP merely bridges the gap from the monitor to MELTT1 and provides a means of transferring control from one side to the other.

9.3. Level 3 MELTT1

Because MELTT is where all the 216A board testing occurs, it is typically here that most of the board diagnostics will be performed. The outermost level of MELTT (MELTT1) consists of several software switches. These switches are used to control the output and flow of the second level of MELTT (MELTT2).

The first question presented here is concerned with the CRT output mode. The choices are minimum output or maximum output, with minimum output being the default value. The minimum output mode of operation will display the name of the test being performed, the completion status of the test (pass/fail) and any error messages presented by the test if a failure occurred. The maximum output mode of operation provides the same information presented by the minimum mode plus the current operation being performed by the controller board through each step of the test, the status read from the command port after each operation is started, and the data presented by the operation status and unit status bytes in the IOPB from the controller. The mode of operation chosen for debugging purposes is totally dependent on the technician's needs. When selecting the mode the user should keep in mind that the minimum output mode of execution is faster but provides less information to the operator for debugging.

The next question presented deals with the program action taken when a test fails. The choices are to halt testing on a failure or to continue on with the next test. Halt testing on failure is the default mode. If continued testing is desired when a failure occurs, the failure is logged in the test execution summary and the next test is executed. If halt on failure is chosen, then when a test fails, the failure is logged in the test execution summary and program returns back to MELTT1 and presents the first question for the CRT output mode again.

However, if the tests are being called up by request from the keyboard (the next question), the halt on failure mode operates in a slightly different manner. In this case, if a test is being looped on, and a failure is encountered, the program does not exit back to the first question, but stays in the same level of operation it is currently in (MELTT2). This will be explained in greater detail later.

The third and final question presented here is the run mode of the tests. The choices are automatically (MELTT1) or by request (MELTT2). The automatic mode is the default and enables the operator to execute all of the tests a variable number of times in a fixed order. It is possible to exclude one or more of the tests from this execution list by entering the by request mode (MELTT2). For the purpose of debugging, the operator will almost always need more control over the test execution, and for this reason, is urged to use the by request mode (MELTT2) of operation.

9.4. Level 4 MELTT2

MELTT2 is the highest level possible in the program flow and is therefore, the most powerful mode for use in board debugging. MELTT2 first signs on with an initial board test procedure. This procedure presents some information of which the operator should be aware. Typing Menu <CR> will provide a command summary. Typing Test Menu <CR> displays a list of the available tests. Pressing the escape key when the prompt "Function or Exit?" is displayed will return the program back to MELTT1. Keeping these three things in mind will make using the debugging tools a more pleasurable experience.

It should also be noted that when a test is called up in this mode, the operator has the ability to loop on this test a variable number of times. If a test is being looped on and you decide to stop execution of the test and abort the loop, simply press the escape key. So pressing the escape key will cause the program to take different actions based on the mode that it is in at the time the key is pressed.

When troubleshooting a board, it is recommended that the operator first type in the name of the test which failed and try executing it again. If the failure remains, look at the contents of the IOPB and command ports for possible clues as to what function was being performed, and the status received for the error. This can be seen by operating the test in the maximum output mode or by requesting that these data fields be displayed as will be seen later.

The routines provided in the menu are by far the best available to the operator for board troubleshooting. In order to effectively use these routines, the operation and function of each routine must be clearly understood. Below is a list of the routines available and a description of each one's operation. Keep in mind that these routines can be used together to display, modify, and operate the 216A controller board and its data structures for more effective debugging.

The Display:

```

-----
|           Function or Exit ?           |
-----

```

should appear on the screen.

Type : Menu<CR>

The Display:

```

-----
|                                     |
|           This is a summary of commands for reference           |
|                                     |
|-----|-----|
| Test Menu           | Display IOPB      |
| Ignore              | Display Ports    |
| Recognize           | CCP/WUP Output   |
| Clear Summary       | RAM Read/Write   |
| Summary             | Controller Diagnostic |
| Display Error Status | Single Operation |
| Set Data Buffer      | Previous Function |
| Display Data Buffer  | Change Track     |
| IQC Kennedy         | CLI              |
|                     | Exit             |
|-----|-----|
|                                     |
|-----|-----|

```

should appear on the screen.

This is a list of all the available routines to be performed for extended control of the 216A board. Each routine is called up by typing in the name of the routine as it appears in the menu.

Test Menu

Test Menu provides a list of the available tests for the 216A board. Remember that these are only the tests which have been pre-written and included in the operating system. It is possible to use the other routines in the menu to step through your own test which has been written "on the fly". To call up an individual test which is listed in the test menu, simply type in the English name for the test as it appears in the test menu; not the hexadecimal number. The number is for use in the CLI routine listed in the menu and will be discussed later.

Ignore

Ignore enables the operator to exclude a test from execution. When the ignore routine signs on simply answer the questions presented by selecting the number of the test which you want to be ignored or by typing a carriage return and aborting the operation. Ignoring a test will cause this status to be reflected in the summary for that particular test. In the request mode (MELTT2), typing in the name of a test which is ignored will cause no action to take place. The program returns the prompt "Function or Exit?". If the tests are then run automatically by entering MELTT1 and answering the questions, the ignored test will not be executed by the automatic routine. Note that ignoring some tests can affect the results of others. The load tape test must always be executed after the controller is reset before any reads, writes, spaces, etc. can be performed. Also it cannot be executed again without failing until an unload tape has been issued or the board has been reset.

Recognize

Recognize allows the operator to include a test from the list of tests which are currently being ignored. This can be accomplished by typing in the number associated with the test in the list or, to abort the operation, type a carriage return. Recognize reverses the affect caused by ignore. If no tests are currently being ignored, the list is empty and the program returns the prompt "Function or Exit?".

Clear Summary

Clear summary clears out all the error status registers for the tests on the 216A controller board. This routine prints the message "Summary has been cleared" and returns the prompt.

Summary

Summary provides the operator with a running count of the number of test executions and failures. The summary is broken into four sections; one section for each track of the tape. This is to determine if the boards continually fail the same tests on certain tracks which could indicate a hardware/software problem on either the controller board, the tape drive, or the data cartridge itself. The current track for each summary is indicated at the bottom of the summary. The summary also indicates which tests have been ignored from execution. It should be noted that the summary is updated based on the current track the program is on. Therefore, if you want the summary to be incremented for track two, you should first change the program to track two (see change track command below) before those tests are executed. Also note that some tests will change the track for you (track select tests) which will cause all test executions following this operation to be incremented on the new track.

Display Error Status

Display Error Status provides the operator with the current error status from the 216A as indicated by the iSBC-216A External Product Specification. This status is updated by the 216A following the completion of each operation. Note that until the controller board is reset, this field may contain random data.

Set Data Buffer

Set Data Buffer allows the operator to change the contents of a one hundred byte data buffer to a desired hexadecimal value. Modification can be made on a single memory location or to a group of locations. When the changes have been made to the data buffer, the contents of the buffer are displayed. This routine is useful when used in conjunction with the single operation routine for writing and reading individual data patterns to and from the controller.

Display Data Buffer

Display Data Buffer allows the operator to view the current contents of the one hundred byte data buffer. This routine is also useful when used with the single operation routine.

IQC Kennedy

IQC Kennedy was originally intended for use in IQC for locating and correcting problems with the Kennedy Tape Drive. This routine downloads all of the iSBC-216A internal status structures into host memory and pulls out the data relating to the Kennedy function code, position status, and summary status. It then interprets this information as indicated by the Kennedy Tape Drive Model 6455 Programming Manual. This routine can be used if problems resulting from drive malfunctions occur. It bridges the gap from controller to drive and provides a window into the tape drive which can often indicate corrective action to be taken on a drive failure.

Display IOPB

Display IOPB shows the contents of the most pertinent information in the IOPB field. This should be used when the operator desires to look at the actual bit patterns in the IOPB. The iSBC-216A External Product Specification describes the function of each value and the implications of each bit pattern.

Display Ports

Display Ports provides the operator with the hexadecimal value present at both the Wake up Port and Controller Command Port from the 216A. The Controller Command Port is further interpreted to show the meaning of the current value. The iSBC-216A External Product Specification fully explains the function of each bit and its application in the controller board.

CCP/WUP Output

CCP/WUP Output allows the operator to send a desired pattern to either the Controller Command Port or the Wake Up Port. If you do not wish to send a pattern to one of the ports, typing a carriage return will abort that output operation. It is recommended that a meaningful data pattern be sent to the controller board to avoid the complications caused by erroneous data. The iSBC-216A External Product Specification fully explains the function of each bit and its application in the controller board.

RAM Read/Write

RAM Read/Write enables the operator to perform looping reads or writes to the iSBC-216A on board buffer Ram. The first 16k (0000H to 3FFFH) is reserved by the 216A for internal use, however, by using this routine, it is possible to read or write to any single location within the remaining 48k. This memory area is broken up by the 216A into three (3) 16k buffers (4000H-7FFFH, 8000H-BFFFH, C000-FFFFH). The routine requires information about which buffer is desired and the displacement within that buffer before any memory operations can occur. Remember that each buffer is only 16k bytes long so the maximum displacement within any buffer is 3FFFH. The routine also provides to option of looping on the memory operation or performing it only once as well as displaying the contents of the command and wake-up ports from the controller. Having the port values displayed slows the memory transfer operation by keeping the host processor busy with overhead. The program indicates when the memory operation has begun, allowing the technician to "scope out" the necessary lines on the 216A board. If the routing is looping on the memory operation, pressing the escape key will release the buffer back to the 216A and exit the routine.

Controller Diagnostic

Controller Diagnostic enables the operator to download the internal status structures from the 216A into host memory. Four (4) options are presented for downloading portions of the status structure. It is recommended that the entire status structure table be downloaded into the host (option number 03H). Refer to Level 1 System Monitor for an example of the use of this routine. Note that the chart given in the Level 1 System Monitor section is valid only if the entire status structure table is downloaded (option number 03H).

Single Operation

Single Operation provides the operator with a means of single stepping the iSBC-216A through each operation of an STBL test or any other test routine written by the user. To select an operation such as space backward record or write FM simply type in the hexadecimal number associated with that operation. Some functions require more information such as record/file counts and the number of bytes to be transferred. These questions will come up automatically as they are required by the program. It should also be noted that write record or file operations assume that the data currently in the data buffer is the desired pattern for this operation. The set data buffer routine allows the contents of the data buffer to be modified. Reads will destroy the current contents of the data buffer. The track select command goes to the beginning of the current track. The iSBC-216A External Product Specification provides a description of each 216A function and the data necessary to perform that operation. This routine is useful for walking a test through each step of execution. For instance, the technician could first fill the data buffer with a desired pattern. Then, by using this routine, he could write a record with this data onto the tape then space backward to the beginning of the record. Next, he could clear out the data buffer and read the record which was just written into the buffer and display its contents. The single operation routine will indicate if an operation is not completed. The Error Status Buffer, IOPB, or Ports could be read between each step of the above process to insure that the correct status was being returned. Only a basic understanding of the 216A board operation and the function of each routine is required to perform most testing sequences. It is also important to realize how the STBL Menu routines work together as a useful and flexible debugging tool.

Previous Function

Previous Function shows the operator what the last operation performed by the 216A was as indicated by the IOPB data field.

CLI

CLI enables the operator to enter commands using the STFS form of syntax. The prompt "*" appears on the screen when CLI is activated. For example:

```
T 0, 2, 4 to 7, 9 to B <CR>
```

will perform tests 0, 2, 4, 5, 6, 7, 9, A, and B. The test number corresponds to the number of each test as indicated in the test menu. When entering a group of tests as in the above line, the tests are not necessarily executed in the order they are given. For instance, if the board is reset, data transfers to the tape drive cannot occur before a load tape command is issued. The program realizes this and performs the load tape command before doing the data transfers, provided the load tape was also entered in the list. CLI also supports a repeat function, Ignore, Recognize, and SUM all with the same command syntax as STFS. To terminate the CLI routine, type Exit <CR> and the prompt "Function or Exit ?" should appear on the screen. The English command syntax is now activated.

Change Track

Change Track provides the operator with a method of selectively changing the tape position to any of the four possible tracks. The beginning or end of the desired track can also be specified for greater flexibility. The error status buffer and IOPB are automatically updated for the new track position by the 216A. This routine will also indicate if a failure occurred and if the desired track was not selected.

Exit

Exit terminates the execution of MELTT2 and turns control of the host over to the GPCP.

10. Drive Diagnostics and Adjustments

This section describes the online and offline diagnostics routines used to isolate faults within the 6455 tape subsystem. Remove the cover to the drive and power supply bay to provide easy access to the tape transport and power supply.

10.1. Power

1. Remove the power connector from the tape transport.
2. Using a multimeter, measure the voltage present at the power connector to the tape transport. The diagram below shows the power connections as at the power plug.
3. Adjust the voltage from the power supply as required to provide the correct voltage levels at the connector plug.
4. Insert the power connector back into the tape transport.

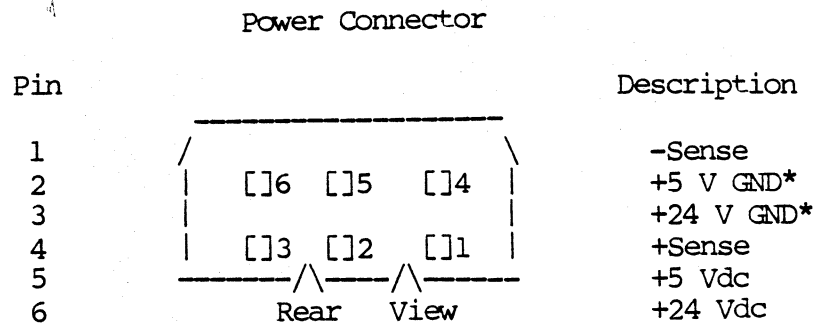

* +5 V and +24 V ground lines should be tied together at the power supply.

10.2. Online Diagnostics

The formatter performs a self-test routine to each load command. Successful completion of the self-test is required before the rest of the load sequence is allowed to continue. The self-test routine is a loop write and read of a file mark. This effectively stimulates about 80 percent of the formatter circuitry, including the data separation circuit. If self-test fails, further offline testing is necessary.

10.3. Offline Diagnostics

To select the offline diagnostics, switch 7 of the eight-position DIP switch (SW1) located on the formatter of the tape transport must be set to the ON position. Ten test routines are then available. Prior to running of these tests a kernel (sanity) test should be run on the 8035 microprocessor and the associated PROM. This test ascertains that the heart of the system is functional, and ready to execute the selected diagnostics.

1. Disconnect the interface cable from the host to protect the formatter interface drivers.
2. Set switch 7 to the ON position.
3. Check the tape data cartridge to guarantee it is NOT in the SAFE position.
4. To run a different test, set switch 8 ON then OFF to reset the formatter.

Offline Diagnostics Switch Setting Chart

Tape Drive Tests

Test	Switch Setting SW 4321
Continuous Load	0000
Ramp Adjust	0001
Tape Speed Adjust	0010

System Tests

Test	Switch Setting SW 4321
Write File Mark, Continuous	0011
Read Continuous	0100
Write Continuous	0101

Formatter Tests

Test	Switch Setting SW 4321
Controller SA	0110
Read Sequencer SA	0111
Write Sequencer SA	1000
Continuous Self Test	1001

NOTE: A "1" indicates that the switch should be in the "ON" position. Remove the tape before running formatter diagnostics.

Tape Drive Tests

10.3.1. Continuous Load Switch Setting = 0000

This routine performs up to 16 continuous LOAD sequences (without the self-test routine). It tests the basic functioning of the 6455 control electronics which allows for the measurement of the duration of the A and B hole signals.

10.3.2. Ramp Adjust Switch Setting = 0001

This test in combination with the ramp adjust potentiometer (R145) found on the transport control board will adjust the system for proper ramp times. When the proper ramp time is reached the tape will shuttle back and forth. If the ramp time is incorrect the tape will move in the forward direction only.

10.3.3. Tape Speed Adjust Switch Setting = 0010

This routine initiates continuous writing of file marks to allow for adjustment of the tape speed using the speed adjustment potentiometer (R144) on the transport control board. The tape will move in the forward direction until the proper speed is achieved, at which point it will shuttle back and forth.

System Tests

10.3.4. Write File Mark Continuous Switch Setting = 0011

This routine will write file marks continuously on all tracks. If a bad file mark is written, a space reverse will be performed and a write FM extended.

10.3.5. Read Continuous Switch Setting = 0100

This routine will read blocks of data or file marks on all tracks continuously.

10.3.6. Write Continuous Switch Setting = 0101

This routine will write short blocks of data on all tracks continuously. If a bad block is written, a space reverse will be performed followed by a write extended routine. This will be repeated, if necessary, until a good block is written.

Formatter Tests

The formatter tests take advantage of the power of signature analysis (SA) to isolate faults to the component level. Certain jumpers are required to set up the SA tests. These are documented in the Kennedy 6455 Tape Subsystem User's Manual.

10.3.7. Controller SA Switch Setting = 0110

This routine stimulates all the nodes in the controller section of the formatter so that any faults in this section can be isolated down to the component responsible.

10.3.8. Read Sequencer SA Switch Setting = 0111

This routine stimulates all the nodes in the read sequencer section of the formatter so that any faults in this section can be isolated down to the component responsible.

10.3.9. Write Sequencer SA Switch Setting = 1000

This routine stimulates all the nodes in the write sequencer section of the formatter so that any faults in this section can be isolated down to the component responsible.

10.3.10. Continuous Self Test Switch Setting = 1001

This routine performs continuous self-test routines that allow the data separator section including the phase lock loop to be tested and adjusted. This is also a good verification of the functioning of the formatter as a whole.

10.3.11. Short and Long Loads Switch Setting = LXXX

This switch enables the user to select a LONG load which on a load command the drive will fast forward the tape to EOT then back to BOT, or to select a SHORT load which on a load command the drive will rewind to load point. With this switch (switch 5) in the "ON" position the drive will do a SHORT load.

11. Appendix

11.1. Monitor Command List

Key	Function	Description/Syntax
N	Single Step	Executes one user program instruction N{<addr>}{, <addr>}{, ...}<CR>
G	Go	Transfer control to test program with two optional breaks. G{<start addr>}{, <break 1 addr>}{, ...}<CR>
S	Substitute	Substitute Memory s{w}<addr>, <new contents>{, <new contents>}<CR>
X	Examine/ Modify Registers	Displays and modifies hosts CPU Registers X{<reg>{<new contents>}}<CR>
D	Display	Displays contents of a specified block of memory in byte, word or instruction form D{w}<start addr>{, <end addr>}<CR>
M	Move Memory	Moves contents of a memory block M{w}<start addr>, <end addr>, <dest addr><CR>
F	Find	Searches a memory block for a byte or word constant. F{w}<start addr>, <end addr>, <data><CR>
I	Port Input	Inputs and displays byte or word data from port. I{w}<port><CR>
O	Port Output	Outputs byte or word data to output port. O{w}<port>, <data><CR>

11.2. GPCP Command List

The following Commands are available under the GPCP:

Syntax	Description
M <CR>	Enter host monitor
S <CR>	Print test names and executions summary
C <CR>	Clear summary
XI, 2,...,I <CR>	Excludes tests up to I from test 0
X <CR>	Print lists of excluded test
I1, 2,...,I <CR>	Include tests up to I into test 0
I <CR>	Print list of included tests

11.3. List of Available Tests

1. Reset Unit
 - a) Reset Unit
 - b) Initialize Unit
2. Initialize Unit
3. Load Tape
4. Unload Tape
5. Erase Tape
6. Erase Track
7. Space Forward File
8. Space Forward Record
9. Space Backward File
10. Space Backward Record
11. Rewind Tape
12. Read File
13. Read Record
14. Read and Compare Record
15. Write File
16. Write Record
17. Write File Mark
18. Track Select to Beginning
19. Track Select to End
20. Xfer Error Status
21. Diagnostics
22. Interrupt Test
23. Invalid Command
24. I/O Port Addressing
25. Buffer I/O
26. RAM Test
27. Restore Tape
28. Response Port Test
29. IOPB Chain Test
30. Cartridge Interrupt Test

11.4. STBL Test Flowchart

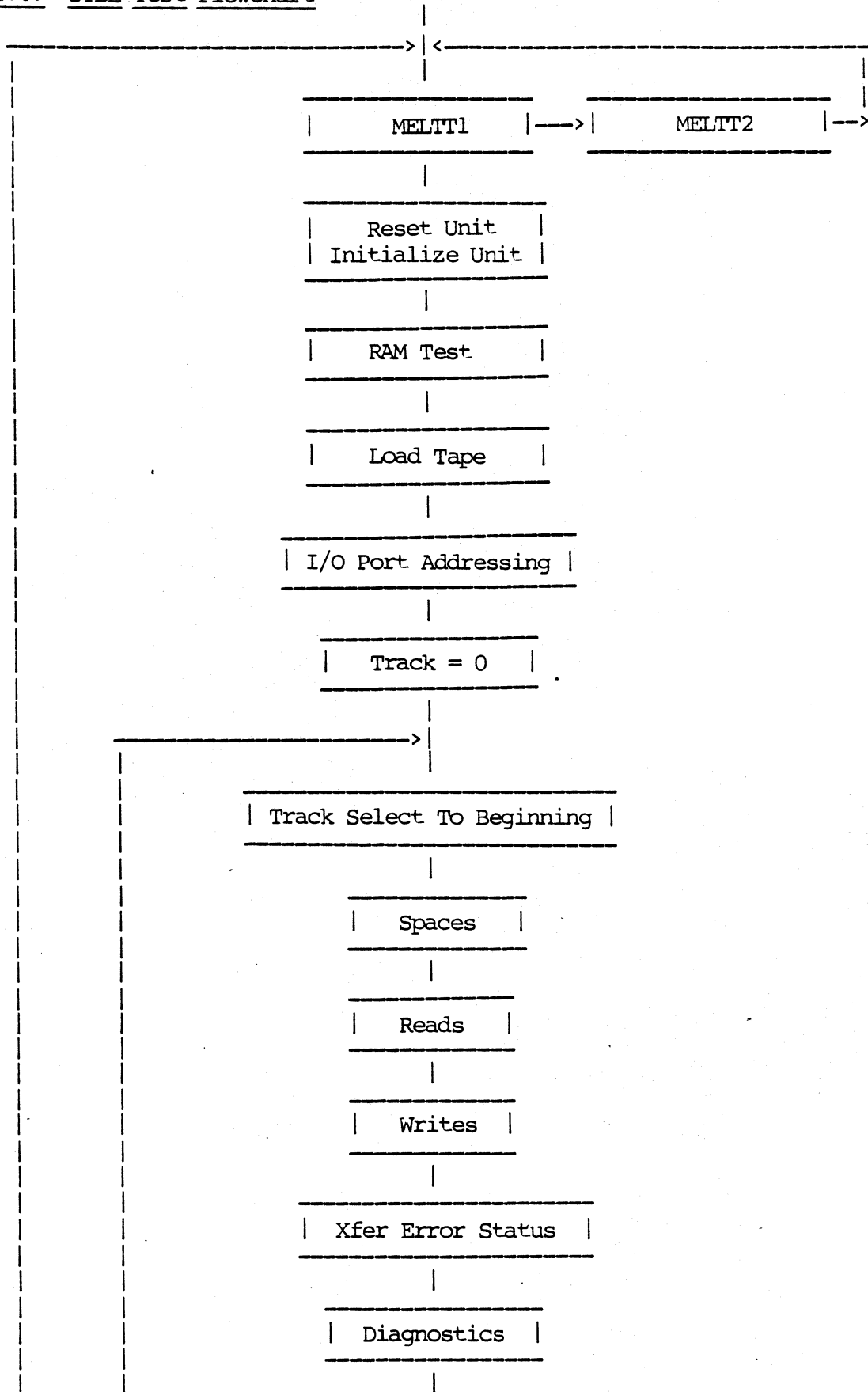

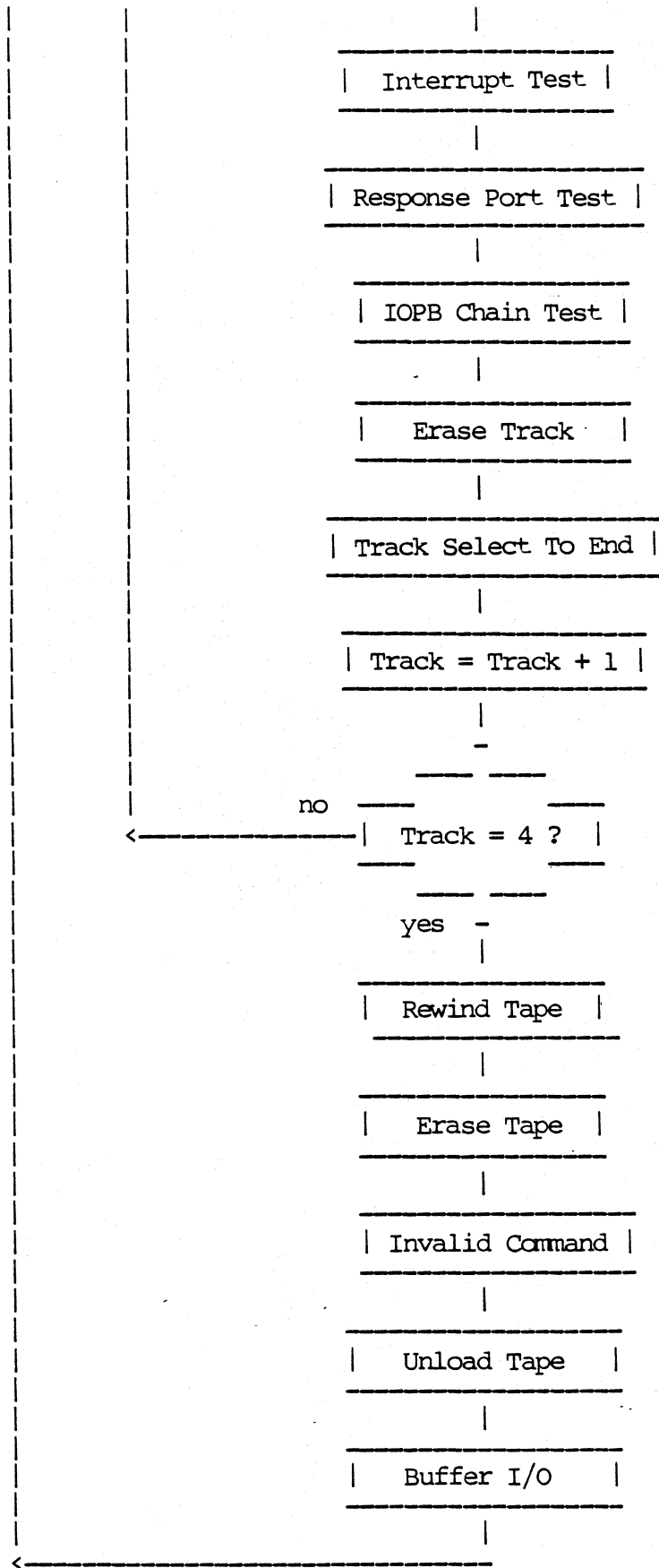

11.5. Description of Tests

Note: After each function is performed the ports and status buffers are checked for the correct response based on the operation being performed and the previous operation. If the returned status does not match with the expected response processing of that test halts and the test will fail. Tests 4 through 24 and 27 through 29 should always be performed after a load tape command has been issued and prior to an unload tape command being issued to the tape drive.

1. Reset Unit — Reset unit performs a software reset at the iSBC-216A and polls the controller Command port for the proper status. Reset unit will automatically perform an initialize unit before it exits.
2. Initialize Unit — Initialize unit sets the CIB and IOPB to an initial state and performs a host/controller linkage. It then issues an initialization command and polls the controller command port for the proper status.
3. Load Tape — The load tape test first attempts to force an error by performing a rewind tape before a load tape has been given to the drive. The rewind tape function should return an operation terminated by fatal error, unit not ready in the IOPB, otherwise the test will fail. For this reason, the load tape test is usually performed following a reset unit, initialize unit, unload tape, or cartridge interrupt test. If the correct status is received from the rewind tape attempt, a load tape command is issued to the drive and the status is again checked for correctness.
4. Unload Tape — The unload tape test performs an unload tape command and polls the iSBC-216A ports and status buffers for the correct response. Then a rewind tape command is given to the drive. This function should return an operation terminated by fatal error, unit not ready in the IOPB, otherwise the test will fail. For this reason, the unload tape test is usually performed following a load tape command being issued to the drive.

5. Erase Tape — The erase tape test first performs an Erase tape function and polls the iSBC-216A ports and status buffers for the correct response.
6. Erase Track — The erase track test first performs a track select to position the tape at the beginning of the current track. The current track is then erased and the status registers in the IOPB are checked for correctness.
7. Space Forward File — The space forward file test checks the controller response to the space forward file command. This is done by first writing two files on the tape and spacing back to the beginning of the files. The space forward file command is then issued followed by a read file command. The data read is then compared to its expected pattern for verification.
8. Space Forward Record — The space forward record test checks the controller response to the space forward record command. This is done by first writing two records on the tape and spacing back to the beginning of the records. The space forward record command is then issued followed by a read record command. The data read is then compared to its expected pattern for verification.
9. Space Backward File — The space backward file test checks the controller response to the space backward file command. This is done by first writing a file on tape and spacing back to the beginning of the file. A read file command is then issued. The data read is then compared to its expected pattern for verification.

10. Space Backward Record — test checks the controller response to the space backward record command. This is done by first writing a record on the tape and spacing back to the beginning of the record. A read record command is then issued to the controller. The data read is then compared to its expected pattern for verification.
11. Rewind Tape — The rewind tape test first issues a track select to the beginning of track 0. This is to position the tape at its beginning. A file is then written at this point followed by the Rewind tape command. The file previously written on the tape is then read and compared to its expected pattern.
12. Read File — The read file test initially writes a file onto the tape. The controller then spaces back to the beginning of the file and performs the read file function. The data read is checked against its expected pattern for verification.
13. Read Record — The read record test writes a record onto the tape. The controller then spaces back to the beginning of the record and performs the read record function. The data read is checked against its expected pattern for verification.
14. Read and Compare Record — The read and compare record test writes three (3) records on the tape each with the data AAH, BBH, CCH, respectively. The controller is then spaces backward to the beginning of the records and performs a read and compare record function searching for ten (10) bytes of the pattern BBH. Upon completion of this operation, the following record is read and the data is compared with CCH for verification. Correct data at this point would indicate that the pattern had been found and the controller functioned properly.
15. Write File — The write file test checks the ability of the iSBC-216A to write data files onto a tape. This test is done by issuing a write file command and then spacing back to the beginning of the file. A read file function is then performed and the data read is checked against its expected pattern for verification.

16. Write Record — The write record test writes a record onto the tape. The controller then spaces back to the beginning at the record and performs a read record function. The data read is compared to its expected pattern for verification.
17. Write File Mark — The write file mark test first writes a file mark on the tape followed by writing a record. Another file mark is then written on the tape and the controller spaces back to the beginning of the first file mark. The controller then spaces forward past the first file mark and reads the file which was written. The data read is then compared to its expected pattern for verification.
18. Track Select to Beginning — This test performs a track select to the beginning of the current track and polls the controller ports and status registers for the proper status.
19. Track Select to End — This test performs a track select to the end of the current track and polls the controller ports and status registers for the proper status.
20. Xfer Error Status — The transfer error status test issues the transfer error status command to the iSBC-216A controller and polls the controller ports and status registers for the proper status.
21. Diagnostics — The diagnostics function of the iSBC-216A is simply a hook to allow additional on board diagnostics in the future. The diagnostics test issues the diagnostics function code to the controller and polls the controller ports and status registers for the proper status.
22. Interrupt Test — The interrupt test first writes a record on the tape and then changes the modifier to allow interrupts to occur on IOPB chain completion. A space backward record is then issued to the controller followed by a space forward record. This tests the ability of the iSBC-216A to send an interrupt to the host processor. A timeout will occur if an interrupt is not seen within three seconds. To conclude the test, the modifier is reset to its original value.
23. Invalid Command — The invalid command test issues all of the possible invalid commands to the iSBC-216A and checks for a hard error, invalid IOPB command in the error status buffer.

24. I/O Port Addressing — The I/O Port addressing test makes use of the MPRO line connected to the iSBC-216A controller board. The Host processor pulls pin 2 of IC 10 E on the 216A low, thus enabling the 8 bit I/O port. The host then attempts to perform a load tape command by setting up the contents of the IOPB and writing a 41H to the 8 bit I/O port. The Host then polls the I/O port for the proper status and checks the status registers to determine if the operation was complete. The Host then performs the same operation using the 16 bit I/O port. The Host then sets pin 2 of IC 10 E back to its original high state and performs those same two operations once again with the 16 bit I/O port enabled.

25. Buffer I/O — The Buffer I/O test checks the capability of the iSBC-216A to transfer Data blocks to/from the host from/to the controller data buffer. This is done by filling the host data buffer with a known data pattern and transferring this data to the controller. The host data buffer is then changed and the controller transfers the original data back to the host. The host then compares the received data with the expected data pattern for verification. At the conclusion of the test the controller data buffer is released.

26. RAM Test — The RAM test is performed in four parts:

- 1) Chip callout test
- 2) Addressing test
- 3) Marching ones test
- 4) Dynamic Refresh test

Upon successful completion of each of the parts, the RAM parity bit is checked to determine if any RAM parity errors have occurred during the execution of that part.

Bit position	0	corresponds to	RAM chip	1B
"	"	1	"	" " " 2B
"	"	2	"	" " " 3B
"	"	3	"	" " " 4B
"	"	4	"	" " " 5B
"	"	5	"	" " " 6B
"	"	6	"	" " " 7B
"	"	7	"	" " " 8B

Parity bit errors correspond to RAM chip 9B

1) Chip Callout Test — All of the RAM is written and compared. Even cells are written with 5AH and odd cells with A5H. The data is then read back and compared with its expected pattern. If a failure is indicated, the bit position of the failure is logged and testing continues until all of the RAM has been checked. This test is then repeated with the odd and even patterns interchanged. The faults are recorded by bit position within the byte. All failures are logged and reported so that the operator will be able to replace and/or troubleshoot RAM chips which have failed.

2) Addressing Test — The address of each 16 bit word is written in its location. The data is then read back and compared with its expected pattern. If a failure is indicated, the expected address and the actual address received are given to host for interpretation. The addresses are displayed to the operator for use in troubleshooting the 216A board.

3) Marching Ones Test — Initially, all the RAM is filled with zeros. Then the following loop is performed for each pattern: Read the first cell and verify that the old pattern is still present. Write the new pattern in that cell and verify that the new pattern is present. Repeat for all other cells, one byte at a time. The patterns used are 00H, 01H, 03H, 07H, 0FH, 1FH, 3FH, 7FH, FFH, FEH, FCH, F8H, F0H, E0H, C0H, and 80H. Faults are recorded by bit position within the byte. If a failure is indicated, the bit position of the failure is logged and testing continues until all of the RAM has been checked. The Bits in error are reported to the operator to enable the replacement and/or troubleshooting of the RAM chips which have failed.

4) Dynamic Refresh Test — All the RAM is filled with FFH. The program then enters a delay loop of 100 milliseconds. Upon completion of the delay loop, each byte of RAM is read and compared with expected pattern for verification. If a failure is indicated, the bit position of the failure is logged and testing continues until all of the RAM has been checked. The bits in error are reported so that the operator will be able to replace and/or troubleshoot RAM chips which have failed.

27. Restore Tape — The restore tape test is used only as a final verification test of the 216A's ability to read, write, and perform track selects. The test first performs a track select to the beginning of track zero. It then writes one file and two records, spaces back to the beginning of the file, and reads back and verifies that the correct data was written and received. This operation is then repeated for the other three tracks.
28. Response Port Test — The response port test checks the ability of the 216A to output a given data pattern to a specified port on the completion of an operation. First a record is written on the tape and the modifier word in the IOPB is set to allow response port communications on a 16 bit port. The controller is then told to space backward one record and the specified response port is polled for the correct data pattern. If the correct response is not present within three seconds, the host will timeout and the test will fail. If the correct response is received the modifier word in the IOPB is again changed to allow communications on an 8 bit port. The 216A is then told to space forward one record and the polling process is repeated. At the conclusion of the test the modifier is reset to its original state.
29. IOPB Chain Test — The IOPB Chain test checks the ability of the 216A to perform IOPB chaining operations. Initially, a record is written on the tape and the Link Forward Pointer is set to the next IOPB in the chain. The first IOPB is set to space backward one record. The second IOPB is set to space forward one record. The operation is then started and the second IOPB is polled for an operation complete in the op status byte.

30.

Cartridge Interrupt Test — This test must be called by request because it requires operator interaction. When the test is entered, a load tape function is performed to allow on interrupt when the cartridge is removed, all interrupts are cleared and the modifier word of the IOPB is set to allow interrupts on media changes. The operator is then prompted to remove the data cartridge and type a carriage return. The host processor then checks for the media change interrupt. The operator is then prompted to insert the data cartridge and type a carriage return. Again the host checks for the media change interrupt. If the interrupt is not seen within three seconds, the Host times out and the test fails. In any case, the modifier is reset to its original value upon completion of the test. Note that after the cartridge interrupt test is performed (or any time the cartridge is removed from the tape drive) a load tape command must be issued to the controller either by request, automatically, or singly.

11.6. Memory Map

