

EK-0TU78-PS-001

TU78 Subsystem

Pocket
Service
Guide

digital

EK-0TU78-PS-001

TU78 Subsystem

Pocket
Service
Guide

1st Edition, May 1981

Copyright © 1981
by Digital Equipment Corporation.
All Rights Reserved.

The reproduction of this material, in part or whole, is strictly prohibited. For copy information, contact the Educational Services Department, Digital Equipment Corporation, Maynard, Massachusetts 01754.

The information in this document is subject to change without notice. Digital Equipment Corporation assumes no responsibility for any errors that may appear in this document.

Printed in U.S.A.

The following are trademarks of Digital Equipment Corporation, Maynard, Massachusetts.

DEC	DECnet	OMNIBUS
DECUS	DECsystem-10	OS/8
DIGITAL	DECSYSTEM-20	PDT
Digital Logo	DECwriter	RSTS
PDP	DIBOL	RSX
UNIBUS	EduSystem	VMS
VAX	IAS	VT
	MASSBUS	

CONTENTS

1 INTRODUCTION

- 1.1 General 1
- 1.2 Subsystem Overview 1
- 1.3 TM78 Assemblies 1
- 1.4 TU78 Assemblies 1
- 1.5 Operator Controls and Indicators 1
- 1.6 Maintenance Controls and Indicators 11
 - 1.6.1 TM78 Controls and Indicators 12
 - 1.6.2 TU78 Controls and Indicators 12
- 1.7 Tools 12
- 1.8 Spares Kit Lists 16
 - 1.8.1 TM78 Spares Kit 16
 - 1.8.2 TU78 Spares Kit 17
- 1.9 Recommended Spares Levels (RSL) 18
 - 1.9.1 Additional TM78 RSL Parts 18
 - 1.9.2 Additional TU78 RSL Parts 18
- 1.10 Related Documents 21
- 1.11 System Diagnostics 23

2 TROUBLESHOOTING

- 2.1 Introduction 24
- 2.2 On-Line Diagnostics 24
- 2.3 In-Line Diagnostics 24
- 2.4 Error Logs 24
- 2.5 Status Indicators for Troubleshooting 24
- 2.6 Error Codes 25
- 2.7 TM78 Maintenance Panel 42
 - 2.7.1 Keypad Function Summary 42
 - 2.7.2 Errors 45
 - 2.7.3 Parameters 46
 - 2.7.4 Maintenance Instructions 55
 - 2.7.5 Sample Maintenance Routine 58
- 2.8 Test Points 58

3 CHECKS AND ADJUSTMENTS

3.1 Parts Replacement 63
 3.2 Quick Reference Adjustment Specification 63

APPENDIX A SUBSYSTEM MASSBUS REGISTERS

APPENDIX B EXTENDED SENSE BYTES

FIGURES

1-1 Dual-Ported TU78 Subsystem 2
 1-2 TM78 Front View 3
 1-3 TM78 Module Layout (Back View) Showing Maintenance Indicators 4
 1-4 TU78 Assemblies (Front View) 6
 1-5 TU78 Assemblies (Back View) 7
 1-6 TU78 Card Cage Showing Maintenance Controls and Indicators 8
 1-7 TU78 Operator Control Panel 9
 1-8 H7422 Power Supply Showing Maintenance Indicators and Controls 13
 1-9 Door Safety Interlock Switch 14
 2-1 TM78 Maintenance Panel 43
 2-2 Sample Write/Read Routine 59
 3-1 TU78 Card Cage Showing Maintenance Switches and Adjustment 73
 3-2 GCR/PE Preamp 1 PCBA Test Points 74
 3-3 Interconnect F1 PCBA 75
 3-4 Vacuum Valve and Pressure Valve 77
 A-1 RH20 and RH780 Addresses 80
 A-2 Control and Status Register 81
 A-3 Data Transfer Interrupt Register 83
 A-4 Tape Control Register 84
 A-5 Drive Type Register 85
 A-6 Tape Unit Status Register 86
 A-7 Motion Interrupt Code Register 87
 A-8 Motion Command Register 88
 A-9 Hardware Control Register 91
 A-10 Configuration/Status Register 92
 A-11 Control Register 93
 A-12 Status Register 94
 A-13 Virtual Address Register 95
 A-14 Byte Counter Register 95
 A-15 Diagnostic Register 96
 A-16 Map Register 97

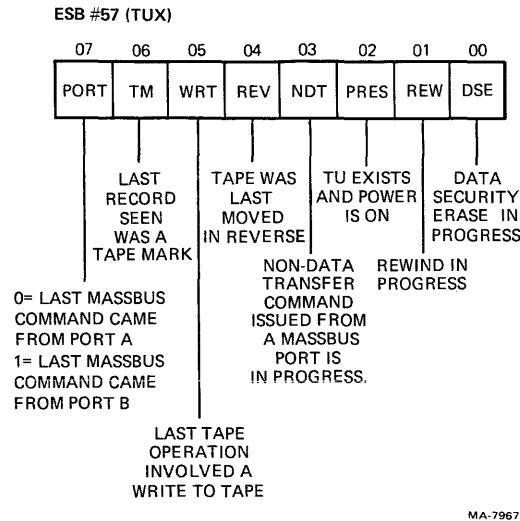

Figure B-17 TU Software Status

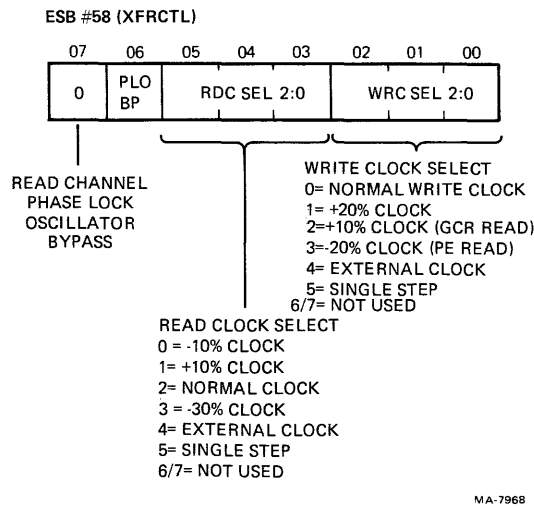
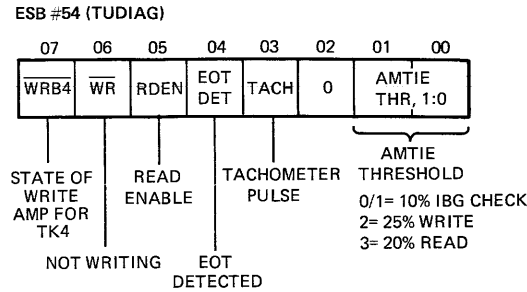
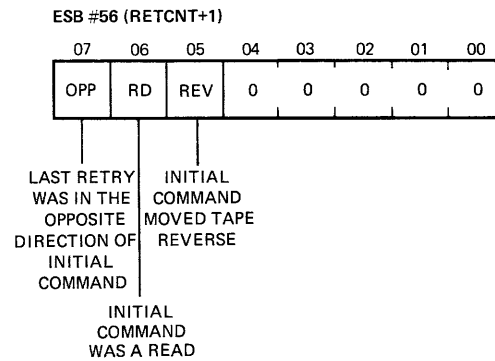

Figure B-18 Transfer Control Byte



MA-7965

Figure B-15 MIA TU Diagnostics Byte



MA-7966

Figure B-16 Retry Control Byte

B-1 Read Path Status Byte 98

B-2 Read Microcontroller Command Byte . . 100

B-3 Parity Read Channel Status Byte 101

B-4 ECC Status Byte 102

B-5 Channel (N) Track in Error Byte 103

B-6 TU Port Status Byte 104

B-7 CAS Port (N) Status Byte 105

B-8 MASSBUS C Bus Status Byte 105

B-9 MASSBUS D Bus Status Byte 106

B-10 Write Microcontroller Error Byte 106

B-11 Interrupt Status Byte 107

B-12 TU78 Status Byte 107

B-13 MIA Status A Byte 109

B-14 MIA Status B Byte 109

B-15 MIA TU Diagnostics Byte 110

B-16 Retry Control Byte 110

B-17 TU Software Status 111

B-18 Transfer Control Byte 111

TU78 Subsystem Detailed

Block Diagram 112

Write Path Troubleshooting Diagram . . 113

Read Path Troubleshooting Diagram . . 113

TABLES

1-1 TU78 Controls 10

1-2 TU78 Indicators 11

1-3 TU78 Maintenance Controls 16

2-1 TM78/TU78 Diagnostics 25

2-2 In-Line Self-Test Microdiagnostics . . . 26

2-3 Troubleshooting Indicator Functions . . 27

2-4 Interrupt Code to Failure Code 29

2-5 Keypad Error/Status Codes 45

2-6 Parameter Items 46

2-7 Maintenance Instruction Codes 55

3-1 Checks/Adjustments When Replacing Parts 63

3-2 Adjustment Specifications 66

3-3 Vacuum and Pressure Valve Components 78

A-1 Data Transfer Function Codes 82

A-2 Nondata Transfer Function Codes 89

B-1 Read Microcontroller Status Codes . . . 99

B-2 Read Microcontroller Command Codes 101

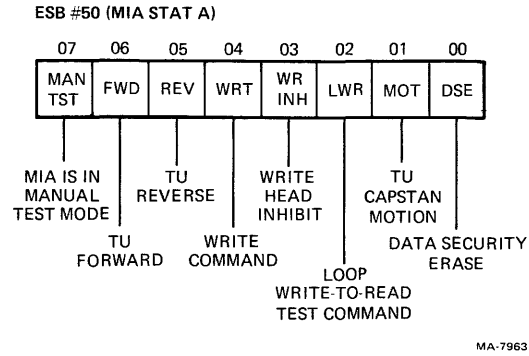

Figure B-13 MIA Status A Byte

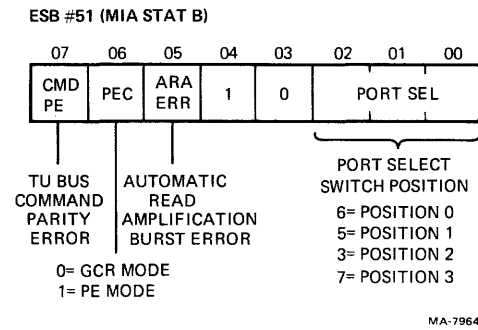

Figure B-14 MIA Status B Byte

•

Byte	Description
50	MIA register 1; MIA status A (Refer to Figure B-13)
51	MIA register 2; MIA status B (Refer to Figure B-14)
52	MIA register 3; serial NR A
53	MIA register 4; serial NR B
54	MIA register 5; diag (Refer to Figure B-15)
55	Retry counter (RETCNT) – This byte is the count of retry interrupt requests given for the tape unit. When this count is zero, the tape unit is not in a retry sequence.
56	Retry control bits (RETCNT + 1) – This byte is used by the microcode to control error recovery. It is meaningful only when the retry counter (byte 55) is not zero. (Refer to Figure B-16)
57	TU software status (TUx). This byte contains information about the tape drive. (Refer to Figure B-17)
58	Transfer control word (XFRCTL) – This byte contains control information used by data transfer commands. (Refer to Figure B-18)
59	Retry suppress and format control (XRETRY). This byte contains the contents of the left half of the MASSBUS register, which contains the retry suppress bit, format, and skip count.
60	Keypad enable flag (ENAON) – This byte is not zero when the keypad is enabled.

1 INTRODUCTION

1.1 GENERAL

This document is designed for use by a person trained to service a TU78 subsystem. A TU78 subsystem is made up of a MASSBUS controller (RHXX), a TM78 formatter, and a TU78 tape transport. Procedures are short, and support a maintenance philosophy of module replacement.

This chapter presents an overview of the formatter and transport for quick review. Chapter 2 is troubleshooting information. Use of error logs, diagnostics, and maintenance panel features allow rapid location of malfunctions. Chapter 3 lists all adjustments in quick reference format.

Programming information is not provided but register summaries for each hardware family type are found in Appendix A. Appendix B lists the extended sense registers available in the diagnostic and error log printouts.

1.2 SUBSYSTEM OVERVIEW

The TU78 subsystem is shown in Figure 1-1. The example shown is a dual-ported TM78 formatter, controlling four TU78 transports. A detailed block diagram of the subsystem may be found on the foldout at the end of this book.

1.3 TM78 ASSEMBLIES

Major TM78 assemblies are shown in Figures 1-2 and 1-3.

1.4 TU78 ASSEMBLIES

Major TU78 assemblies are shown in Figures 1-4, 1-5, and 1-6.

1.5 OPERATOR CONTROLS AND INDICATORS

All operator controls and indicators are on the TU78 control panel. Figure 1-7 shows the panel, Table 1-1 lists the controls and their functions, and Table 1-2 lists the indicators and their functions.

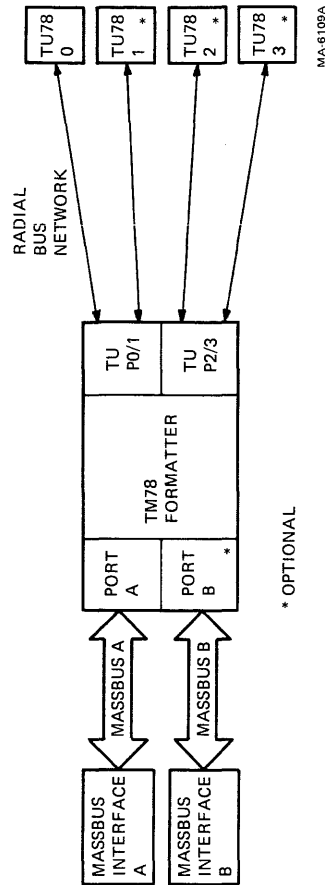

Figure 1-1 Dual-Ported TU78 Subsystem

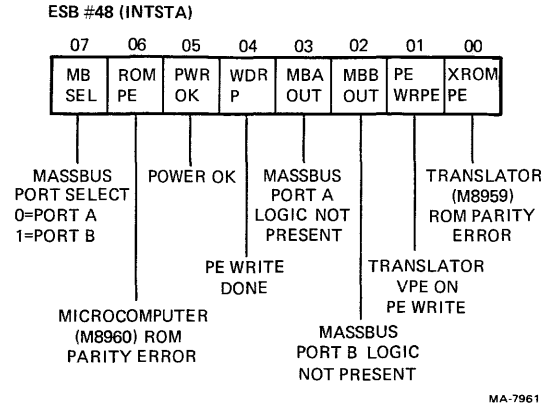

Figure B-11 Interrupt Status Byte

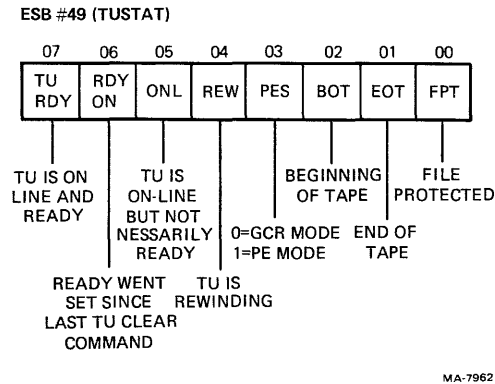

Figure B-12 TU78 Status Byte

Byte	Description
48	Hardware register 340; interrupt status (Refer to Figure B-11)
49	MIA register 0; TU78 status (Refer to Figure B-12)

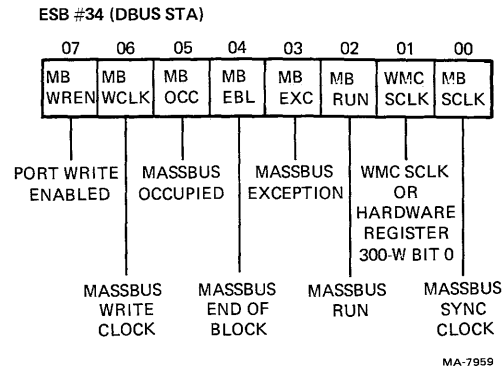

Figure B-9 MASSBUS D Bus Status Byte

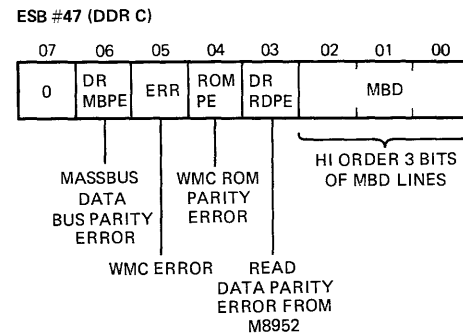

Figure B-10 Write Microcontroller Error Byte

Byte	Description
44	Hardware register 326; ECODE counter <15:8>
45	Hardware register 330; DDR/MBD A
46	Hardware register 331; DDR/MBD B
47	Hardware register 332; WMC errors (Refer to Figure B-10)

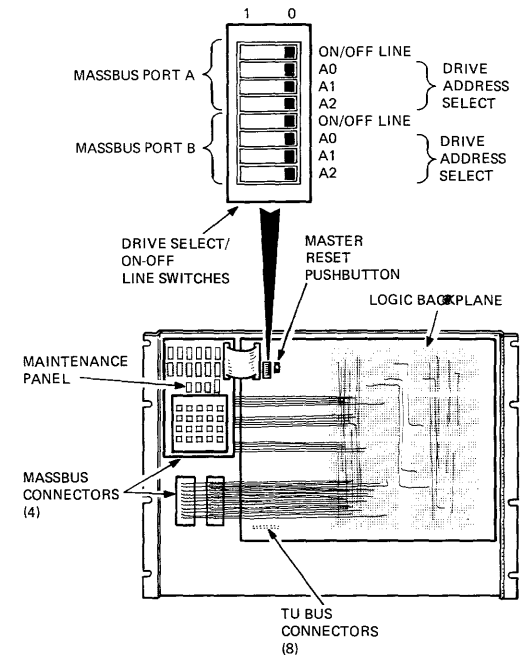

Figure 1-2 TM78 Front View

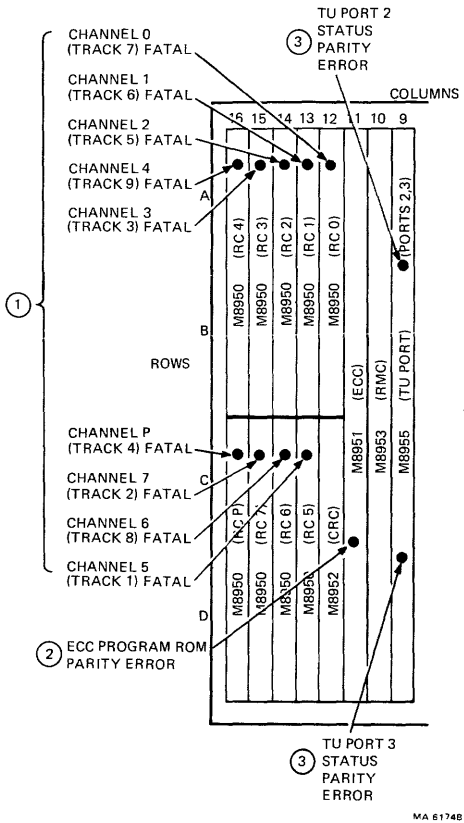

Figure 1-3 TM78 Module Layout (Back View) Showing Maintenance Indicators (Sheet 1 of 2)

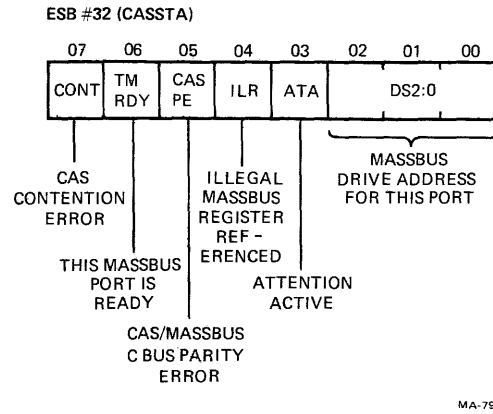

Figure B-7 CAS Port (N) Status Byte

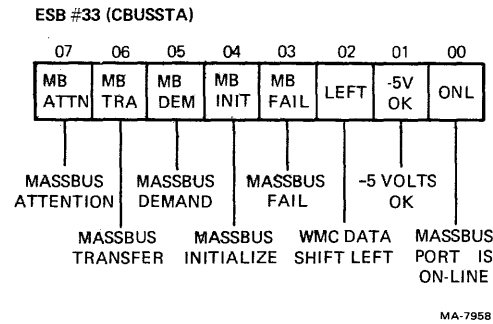

Figure B-8 MASSBUS C Bus Status Byte

Byte	Description
39	Hardware register 324; byte counter <7:0>
40	Hardware register 324; byte counter <15:8>
41	Hardware register 325; PAD counter <7:0>
42	Hardware register 325; PAD counter <15:8>
43	Hardware register 326; ECODE counter <7:0>

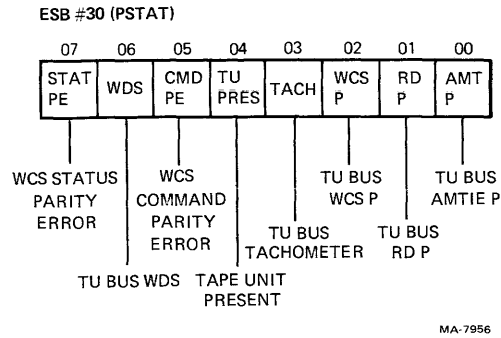

Figure B-6 TU Port Status Byte

Byte	Description
27	Hardware register 50; channel P TIE bus (Refer to Figure B-5)
28	Hardware register 60; TIE bus
29	Hardware register 104; AMTIE (TU Bus)
30	Hardware register 110; PORT status (Refer to Figure B-6)
31	Hardware register 114; read data
32	Hardware register 240; CAS status (Refer to Figure B-7)
33	Hardware register 241; CBUS status (Refer to Figure B-8)
34	Hardware register 300; DBUS status (Refer to Figure B-9)
35	Hardware register 320; WMC status
36	Hardware register 321; TU select 0
37	Hardware register 322; TU select 1
38	Hardware register 323; write data

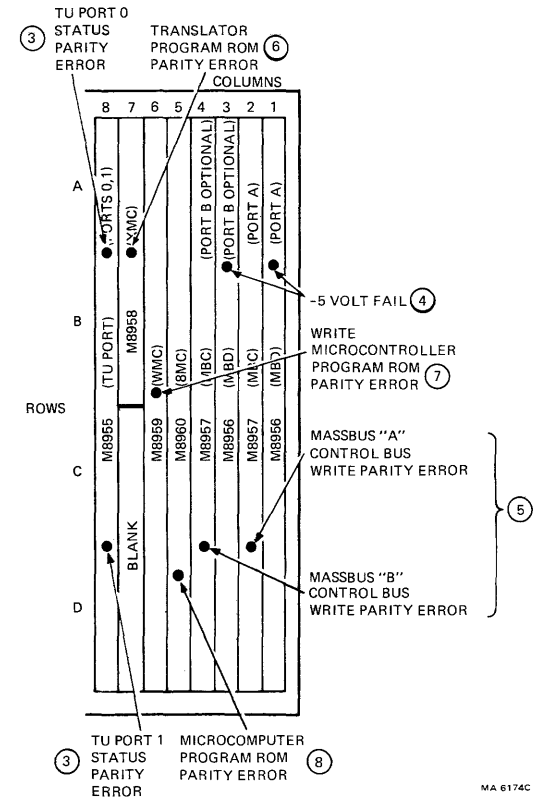

Figure 1-3 TM78 Module Layout (Back View) Showing Maintenance Indicators (Sheet 2 of 2)

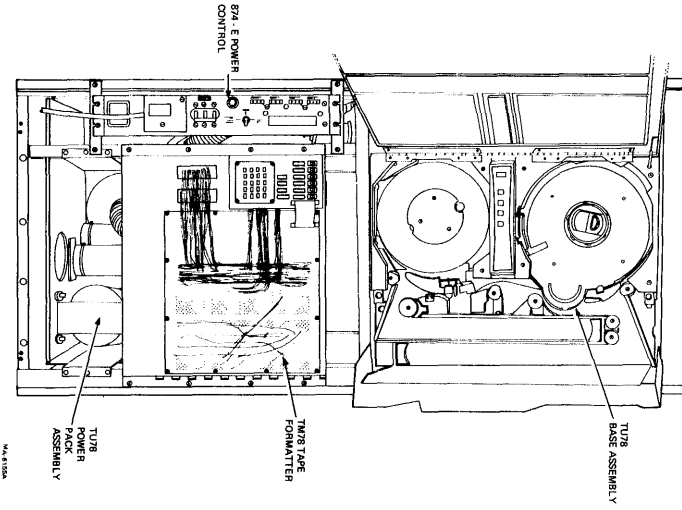
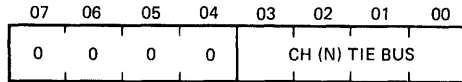

Figure 1-4 TU78 Assemblies (Front View)

ESB #19-27 (CHNTIE)



AMTIE
PHASE TIE

GCR=ILLEGAL 5:4
PE=DEAD TRACK

STAT=0*, POINTER MISMATCH IN GCR
STAT=1*, ANY POINTER OCCURRED

*STATISTICS BIT
(BIT 1 IN HARDWARE
REGISTER 011-W;RPCTL)

MA-7955

Figure B-5 Channel (N) Track in Error Byte

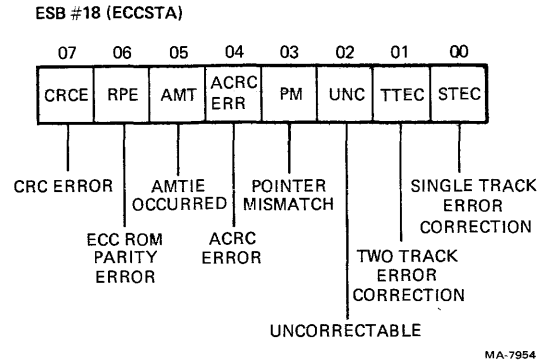

Figure B-4 ECC Status Byte

Byte	Description
17	Hardware register 31; corrected data (CH 7:0)
18	Hardware register 32; ECC status (Refer to Figure B-4)
19	Hardware register 40; channel 0 TIE bus (Refer to Figure B-5)
20	Hardware register 41; channel 1 TIE bus (Refer to Figure B-5)
21	Hardware register 42; channel 2 TIE bus (Refer to Figure B-5)
22	Hardware register 43; channel 3 TIE bus (Refer to Figure B-5)
23	Hardware register 44; channel 4 TIE bus (Refer to Figure B-5)
24	Hardware register 45; channel 5 TIE bus (Refer to Figure B-5)
25	Hardware register 46; channel 6 TIE bus (Refer to Figure B-5)
26	Hardware register 47; channel 7 TIE bus (Refer to Figure B-5)

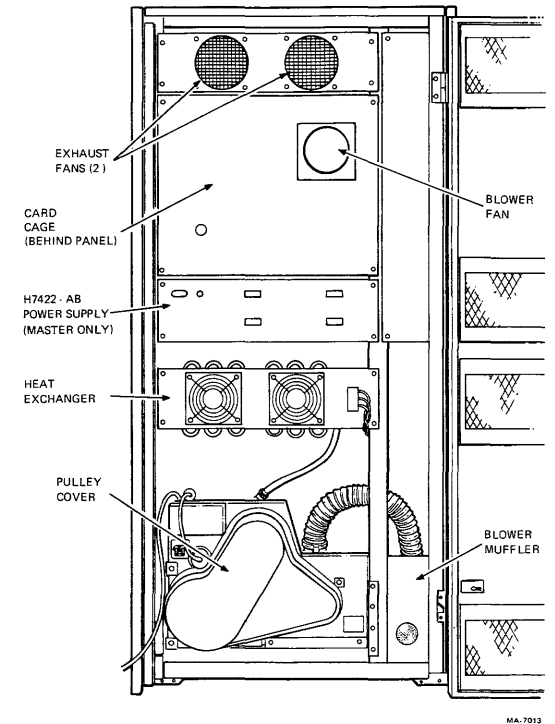

Figure 1-5 TU78 Assemblies (Back View)

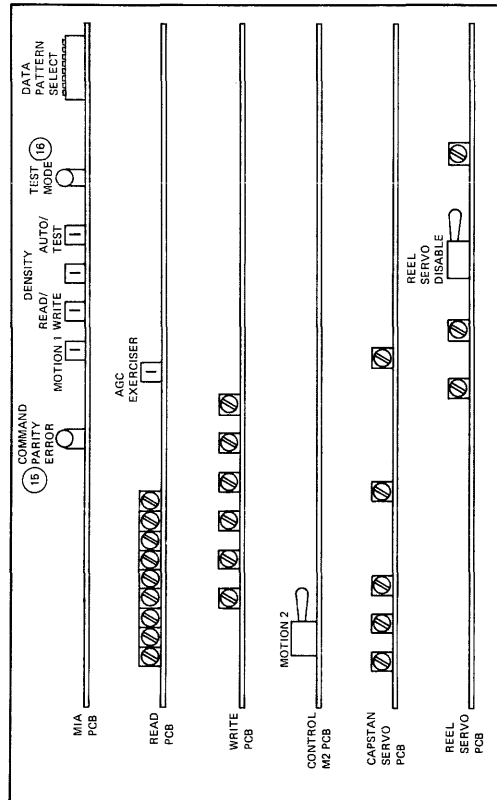

Figure 1-6 TUJ78 Card Cage Showing Maintenance Controls and Indicators

Table B-2 Read Microcontroller Command Codes

CMD Code	Description
00	NOP
01	Interblock read
02	Test PE ID burst
03	Test GCR ID burst
04	Test ARAID burst
05	Test tape mark
06	Test ARA burst
07	Normal NON-BOT read
10	Run RMC self-test
11	Test unknown ID burst
12	Run read channel micro's test
13	Diagnostic read command
14	Run read channel self-test
15	Run clear all RMC test program
16	Run ECC self-test program
17	Find gap

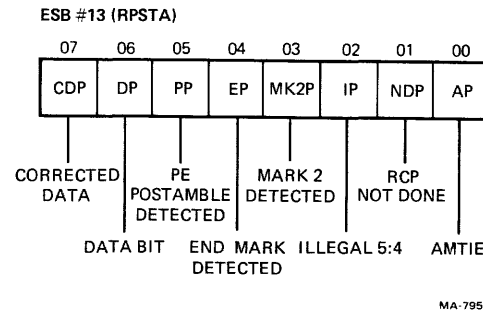

Figure B-3 Parity Read Channel Status Byte

Byte	Description
13	Hardware register 25; RC PAR bits (CH P) (Refer to Figure B-3)
14	Hardware register 26; postamble detected (CH 7:0)
15	Hardware register 27: data (CH 7:0)
16	Hardware register 30; CRC

Table B-1 Read Microcontroller Status Codes (Cont)

Status	Meaning
236	Read path fault 2; 7 or more M8950 BOARDS found illegal 5 to 4 translations.
241	Unexpected IBG in data; probably creased tape (7 or more AMTIES active)
261	Postamble long
262	Postamble short
377	OK

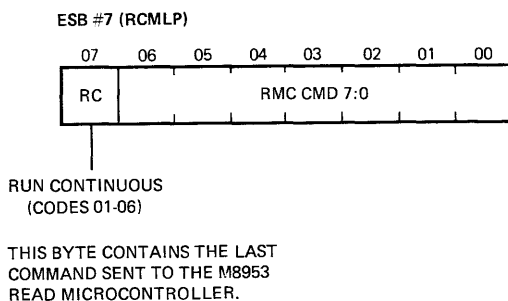

Figure B-2 Read Microcontroller Command Byte

Byte	Description
11	Hardware register 23; mark 2 (CH 7:0)
12	Hardware register 24; end mark (CH 7:0)

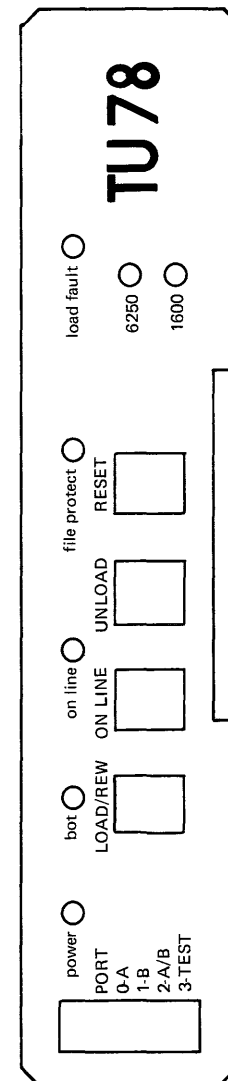

Figure I-7 TU78 Operator Control Panel

Table 1-1 TU78 Controls

Control	Function										
Port Select Switch	It selects the MASSBUS I/O port(s) allowed to send commands to this tape transport.										
	<table border="1"> <thead> <tr> <th>Switch Position</th> <th>Function</th> </tr> </thead> <tbody> <tr> <td>0</td> <td>Transport connected to MASSBUS port A</td> </tr> <tr> <td>1</td> <td>Transport connected to MASSBUS port B</td> </tr> <tr> <td>2</td> <td>Transport connected to both MASSBUS ports A and B</td> </tr> <tr> <td>3</td> <td>Transport disconnected from both MASSBUS ports and placed in maintenance mode (available to TM78 formatter maintenance panel)</td> </tr> </tbody> </table>	Switch Position	Function	0	Transport connected to MASSBUS port A	1	Transport connected to MASSBUS port B	2	Transport connected to both MASSBUS ports A and B	3	Transport disconnected from both MASSBUS ports and placed in maintenance mode (available to TM78 formatter maintenance panel)
Switch Position	Function										
0	Transport connected to MASSBUS port A										
1	Transport connected to MASSBUS port B										
2	Transport connected to both MASSBUS ports A and B										
3	Transport disconnected from both MASSBUS ports and placed in maintenance mode (available to TM78 formatter maintenance panel)										
LOAD/REW	<p>It starts one of three sequences</p> <ol style="list-style-type: none"> 1. With no tape in path, it initiates a load sequence. 2. With tape in path but not tensioned, it starts a midreel load sequence. In a midreel load sequence the tape loads and runs in reverse direction to BOT. 3. With tape in path and tensioned, and the transport off-line, the tape rewinds to BOT. If the tape is at BOT or if the transport is on-line, no action occurs. 										
ON LINE	It switches the transport off-line or on-line.										
UNLOAD	If the TU78 is off-line, it causes the tape to rewind and unload. If the tape is at BOT, it unloads. If the TU78 is on-line, button has no effect.										
RESET	Terminates all functions and clears a load fault.										

Table B-1 Read Microcontroller Status Codes

Status	Meaning
Status resulting from ECC self-test command	
101	ECC sequencer passed self-test
102	ECC sequencer failed self-test
Status resulting from an M8953 self-test	
103	Read path passed self-test
104	Read path failed self-test
Status resulting from an M8950 self-test command	
106	Read channel tests all passed
Status resulting from a clear all test command for velocity testing of drive by microcode	
1	First tach pulse
201	Last tach pulse (eleventh) (ten spaces)
Status resulting from a sample density command	
210	NOT CAPABLE found
211	GCR ID found
212	PE ID found
Status resulting from a write test of IBG, PE ID, GCR ID, ARA ID, or ARA burst	
220	Bad status (write test)
Status resulting from a tape mark test command	
222	Good tape mark found on tape status
Status resulting from a NON BOT command (read or write FWD or REV, GCR or PE)	
230	ARA ID found (not record or TM)
231	Tape mark found
234	Preamble end not found
235	Read path fault 1, too many M8950s have been fataled to continue record processing

APPENDIX B EXTENDED SENSE BYTES

Byte	Description
1	Command code being executed on last error
2	Interrupt code from last error
3	Failure code last error
4	Hardware register 0; read path write fail bits
5	Hardware register 1; read path diagnostic bits
6	Hardware register 2; read path status (Refer to Figure B-1)
7	Hardware register 3; read path command loop (Refer to Figure B-2)
8	Hardware register 20; AMTIES (CH 7:0)
9	Hardware register 21; RC DONE (CH 7:0)
10	Hardware register 22; illegal 5-4 (CH 7:0)

ESB #6 (RSTAT)

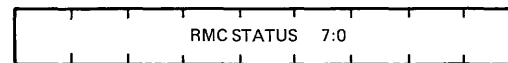

READ PATH MICROCONTROLLER STATUS CODES ARE RETURNED IN THIS BYTE. TABLE B-1 IDENTIFIES EACH CODE AND IT'S MEANING.

MA-7951

Figure B-1 Read Path Status Byte

Table 1-2 TU78 Indicators

Indicator	Meaning
Power	DC and secondary ac power are present.
BOT	Tape is at BOT.
On Line	TU78 is on-line. The transport returns to the off-line mode if any of the following occur. <ol style="list-style-type: none"> 1. ON LINE button is pressed. 2. External rewind unload command is received. 3. Vacuum column interlock is broken. 4. AC power is lost. 5. RESET button is pressed. 6. Front door opens.
File Protect	Tape reel without a write enable ring has been loaded on the transport.
Load Fault	Load fault has occurred. <ol style="list-style-type: none"> 1. Autoload sequence has failed to load a tape from a 267 mm (10.5 in) reel after two tries. 2. Load sequence has failed to load tape from a 216 mm or 178 mm (8.5 in or 7 in) reels.
1600	Tape transport is set to read or write at 1600 bits/in (PE mode).
6250	Tape transport is set to read or write at 6250 bits/in (GCR mode).

1.6 MAINTENANCE CONTROLS AND INDICATORS

Maintenance controls and indicators may be found on the TM78 logic gate (front and back), the TM78 power supply (H7422), the TU78 logic cage, and the front of the TU78 base assembly.

1.6.1 TM78 Controls and Indicators

Figure 1-2 shows the front of the TM78 logic gate and details the maintenance controls. The maintenance panel is described in Chapter 2. To the right of the maintenance panel is a DIP switch matrix. The DIP switches select the MASSBUS drive address for both ports and sets either or both ports on or off-line. A dual port TM78 is considered off-line for maintenance purposes only when both ports are placed off-line.

Figure 1-3 shows the back of the logic gate and details some of the maintenance indicators that may be used for troubleshooting. Table 2-3 lists the indicators and describes their functions.

Figure 1-8 shows the front of the H7422 power supply and details the maintenance indicators and adjustments.

1.6.2 TU78 Controls and Indicators

Figure 1-9 shows a detail of the base assembly and points out the door safety interlock switch. This switch must be defeated to perform certain maintenance adjustments. To defeat the switch pull its actuator arm down and out with a spring hook.

The rest of the TU78 maintenance controls and indicators are on PCBAs in the card cage assembly (Figure 1-6). Table 1-3 lists the TU78 maintenance controls and Table 2-3 lists the indicators.

1.7 TOOLS

In addition to the standard DIGITAL tool kit, the following tools are needed to service the TM78/TU78.

Description	DEC Part Number	Included in Spares Kit
Dual trace oscilloscope with two X10/X1 probes	—	No
Digital voltmeter	—	No
Two multilayer dual-height module extenders	W900	No
Reel motor centering tool	29-23206	Yes

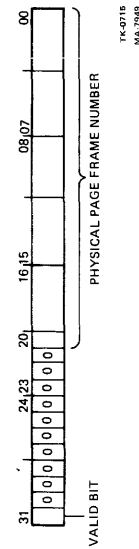

Figure A-16 Map Register

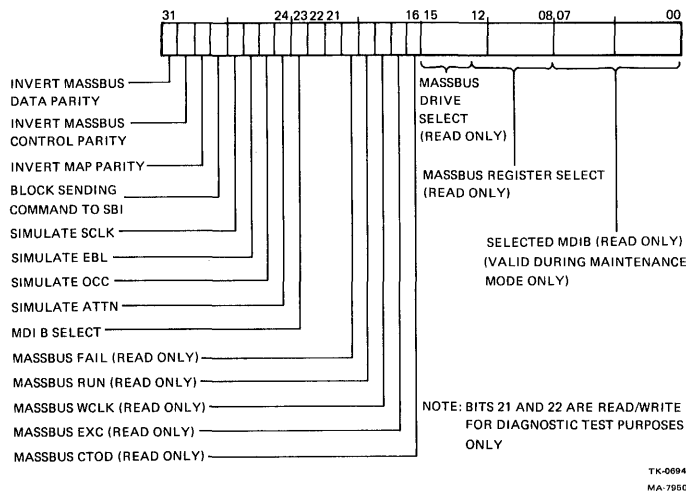

Figure A-15 Diagnostic Register

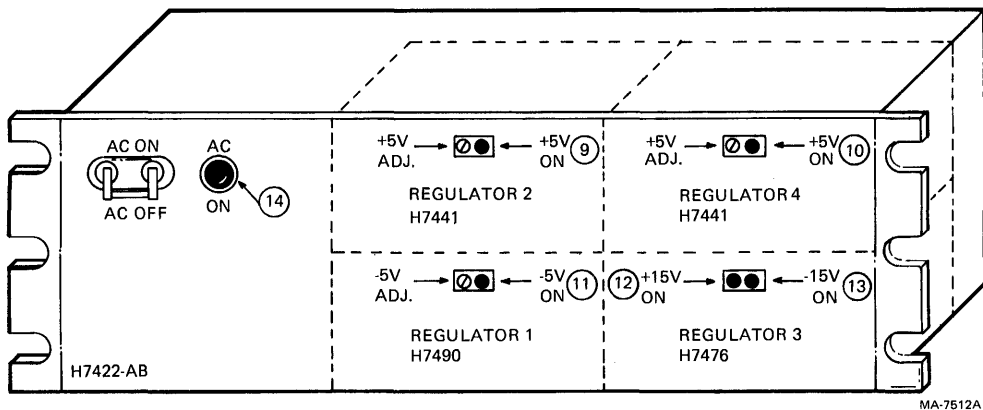

Figure 1-8 H7422 Power Supply Showing Maintenance Indicators and Controls

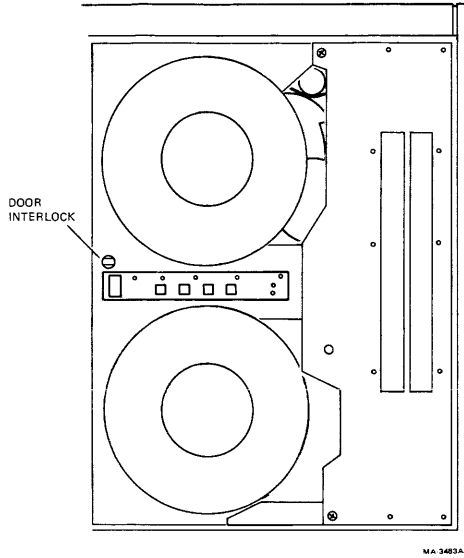

Figure 1-9 Door Safety Interlock Switch

Description	DEC Part Number	Included in Spares Kit
Reel flange locating bar	29-23207	Yes
PCBA extender	29-23218	Yes
Lower restraint tube fitting	29-23228	Yes
Differential pressure gauge (0-40 inch H ₂ O)	29-11650	Yes
Differential pressure gauge (0-5 PSI)	29-11636	Yes

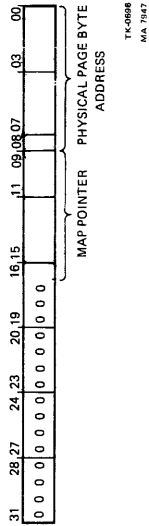

Figure A-13 Virtual Address Register

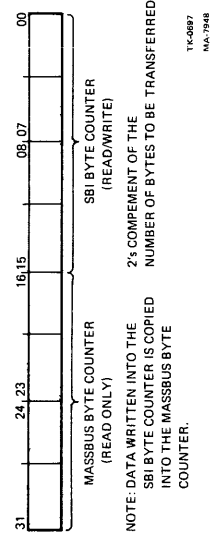

Figure A-14 Byte Counter Register

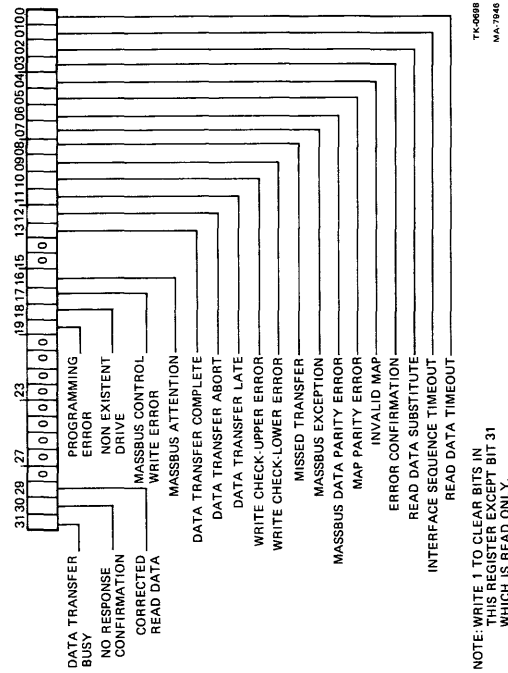

Figure A-12 Status Register

Description	DEC Part Number	Included in Spares Kit
Portable accessory package for gauges (2 needed)	29-11647	Yes
Tachometer (decimal readout)	29-11635	Yes
Tape crimper	47-00038	Yes
Xcelite handle	29-10562	Yes
7 inch extension	29-11625	Yes
5/32 inch × 4 inch Ballpoint hex driver	29-11630	Yes
Master skew tape (1200 ft)	29-19224	No
Magna-See tape developer	29-16871	No
50X microscope with graticule	29-20273	No
Heat sink compound	90-08268	Yes
Inspection mirror (dental type)	29-19663	No
Cleaning kit	TUC01	(comes with TU78)
Standard output tape	29-11691	No

Table 1-3 TU78 Maintenance Controls

Control	Location	Purpose
Motion 1	MIA PCBA	It moves transport forward or reverse when on-line and in manual mode.
Read/Write	MIA PCBA	It selects read or write mode when on-line and in manual mode.
Density	MIA PCBA	It selects 1600 or 6250 BPI density when on-line and in manual mode.
Auto/Man	MIA PCBA	It selects auto (transport connected to formatter) or test mode. When in test (or manual) mode, transport must be on-line for other MIA switches to function.
Data Pattern Select	MIA PCBA	It selects a repeating 8-frame pattern when on-line and in manual mode.
AGC Exerciser	Read PCBA	It allows Read PCBA to lock AGC to the ARA burst, or to run free.
Motion 2	Control M2 PCBA	It moves transport forward or reverse, on or off-line.
Reel Servo Disable	Reel servo PCBA	It disables the reel servo amplifiers so that certain adjustments can be made.

1.8 SPARES KIT LISTS

1.8.1 TM78 Spares Kit (A2-W0342-10)

The following lists the contents of the TM78 Spares Kit.

DEC Part Number	Description
M8950	Read data sync module
M8951	ECC module
M8952	CRC/ACRC module

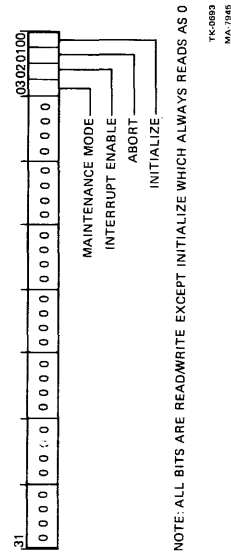

Figure A-11 Control Register

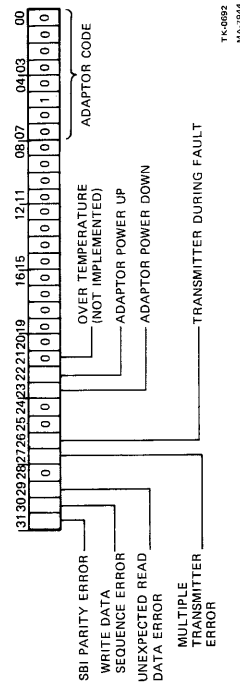

Figure A-10 Configuration/Status Register

DEC Part Number	Description
M8953	Read path microcontroller module
M8955	TU port module
M8956	MASSBUS data interface module
M8957	Common address space module
M8958	Write translator module
M8959	Write micro/byte assembly module
M8960	Microcomputer module
54-14174	Maintenance keypad/display
H7476	Power supply regulator ± 15.0 V
H7490	Power supply regulator -5.0 V
H7441	Power supply regulator $+5.0$ V
54-14192	AC/DC low board

1.8.2 TU78 Spares Kit (A2-W0341-10)

The following lists the contents of the TU78 Spares Kit.

DEC Part Number	Description
29-23766	GCR/PE preamp 1 PCBA
29-23770	Interconnect F1 PCBA
29-23769	MIA PCBA
29-23763	WRITE PCBA
29-23762	READ PCBA
29-23764	Control M2 PCBA
29-23765	Capstan/regulator PCBA
29-23231	Reel servo PCBA
29-23218	Extender PCBA
29-23996	Compressor belt, 50/60 Hz
29-23989	Blower belt, 50 Hz, Lo Altitude
29-23991	Blower belt, 60 Hz, Lo Altitude
29-23220	Muffler
29-23259	Air filter
70-17382-15	15 ft TU bus cable
29-10562	Handle
29-11625	7 inch extension
29-11630	5/32 inch ball-end allen driver
29-11001	Phillips screwdriver blade
29-11635	Tachometer

DEC

Part Number Description

29-11636	Gauge, 0-5 PSI
29-11650	Gauge, 0-40 inch H ₂ O
29-11647	Accessory kit for gauges (2)
29-23206	Centering tool
29-23207	Locating bar
29-23228	Tube fitting

1.9 RECOMMENDED SPARES LEVELS (RSL)

In addition to the spares kit contents, the following parts are recommended to repair 98 percent of all possible failures.

1.9.1 Additional TM78 RSL Parts

The following are additional RSL parts for the TM78.

DEC

Part Number Description

BC06S-25	25 ft MASSBUS cable
12-10930-01	230 Vac fan
12-11079-00	Pushbutton switch
12-11164-04	DIP switch
70-17381-0D	Flat cable
70-17400-00	Backplane

1.9.2 Additional TU78 RSL Parts

The following are additional RSL parts for the TU78.

DEC

Part Number Description

12-17916-02	Fan, tube axial 230 V
29-16280-00	Switch, MICRO
29-23216-00	Sense assy, reel
29-23217-00	Sense assy, pack
29-23236-00	Motor assy, reel

29-23238-00	Switch, pressure
29-23239-00	Switch, pressure
29-23242-00	EOT/BOT assy
29-23243-00	TIP assy
29-23246-00	Transducer assy, vacuum

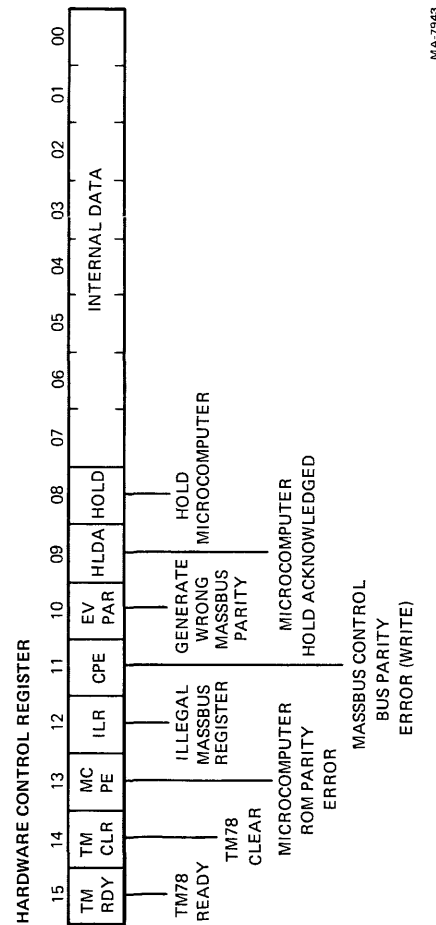

Figure A-9 Hardware Control Register

Table A-2 Nondata Transfer Function Codes (Cont)

Function Code (Go Bit Included)	Name	Description
37	ERG GCR §	Erases three inches of tape, sets GCR
41	Close File PE §	Writes two tape marks, spaces reverse one, sets PE
43	Close File GCR §	Writes two tape marks, spaces reverse one, sets GCR
45	SPACE LEOT	Spaces forward until two tape marks, spaces reverse one
47	SPACE FWD FILE/LEOT	Spaces forward to tape mark, stops if two successive tape marks (logical end of tape)

*Sometimes interrupts when rewind starts; always interrupts after tape motion has stopped.

†Sense registers are valid as long as the ATTN bit is set.

‡Erases at least 3.05 m (10 ft) beyond the EOT marker.

§Recording format is ignored except when tape is at load point (BOT). It is specified by bit 1.

||Do not use after any reverse operation; the TM78 may skip over an LEOT located where direction was reversed.

DEC Part Number	Description
29-23247-00	Circuit breaker
29-23248-00	Valve assy, vacuum
29-23249-00	Valve assy, pressure
29-23250-00	Bearing, air
29-23251-00	Bearing, air
29-23252-00	Bearing, air
29-23257-00	Compressor
29-23280-00	Motor, gear drv
29-23287-00	Motor, ac
29-23297-00	Switch, backwrap defeat
29-23298-00	Blower assy (Below SN SP002386)
29-24013	Blower assy (SN SP002386 and above)
29-23308-00	Relay reed SS 12 Vdc
29-23321-0P	Cable, flat ribbon (AMTIE)
29-23322-00	Thread block 2
29-23323-00	Thread block 4
29-23324-00	Thread block assy
29-23325-00	Thread block assy
29-23326-00	Thread block assy
29-23475-00	Hub reel
29-23767-00	Head, R/W
29-23768-00	Motor assy, capstan
29-23771-00	Controls assy
10-11643-00	18,000 MFD 25V +75-10%
12-14405-00	Door, tape transport, front
29-23208-00	Hub, machined
29-23209-00	Flange, front
29-23211-00	Interconnect D1
29-23215-00	Door assy, buffer box
29-23219-00	Spring, compression
29-23222-00	Spring, bellville
29-23223-00	Washer
29-23241-00	Cleaner, tape
29-23255-00	Guide plate "R"
29-23256-00	Guide plate "C"

DEC Part Number	Description
29-23258-00	Transformer
29-23279-00	Filter, RFI
29-23283-00	Guide, Air
29-23284-00	Hub, motor 50 Hz
29-23285-00	Hub, motor 60 Hz
29-23286-00	Catch, spring
29-23288-00	Receptacle, fastener
29-23309-00	47000 MFD 15 W VDC +75%-10%
29-23310-00	61000 MFD 50 W VDC +100%-10%
29-23311-00	RECT, BRDG 25 A 100 PN
29-23312-00	RECT, BRDG 10 A 100 A
29-23320-00	330 20 W 10% WW
29-23361-00	Cap plug
29-23655-00	Kit, vac hose/tubing
70-17143-00	Fan assembly TU78
90-07221-00	Fuse, reg blow, 5 A, 250 V
90-08835-00	Fuse, reg blow, 20 A, 32 V
90-08838-00	Fuse, reg blow, 10 A, 32 V
29-11691-00	Tape MSTR OTPT 1200X1/2
29-16871-00	Magnasee
29-19224-00	Tape, master skew 1200
29-20273-00	Microscope 50 X
47-00038	Tape crimper
90-08268	Thermal compound

Table A-2 Nondata Transfer Function Codes

Function Code (Go Bit Included)	Name	Description
03	NO OP	Generates a unique NO OP interrupt code
05	Unload	Unloads tape and interrupts immediately
07	Rewind*	Rewinds tape and interrupts when done
11	Sense†	Puts status information into CAS
13	Data Security Erase‡	Erases remainder of tape and rewinds
15	WTM PE §	Writes phase-encoded tape mark
17	WTM GCR §	Writes GCR tape mark
21	SP FWD REC	Spaces forward record, stops if tape mark
23	SP REV REC	Spaces reverse record, stops if tape mark or BOT
25	SP FWD FILE	Spaces forward file (to tape mark)
27	SP REV FILE	Spaces reverse file (to tape mark)
31	SP FWD EITHER	Spaces forward either record or file
33	SP REV EITHER	Spaces reverse either record or file
35	ERG PE §	Erases three inches of tape, sets PE

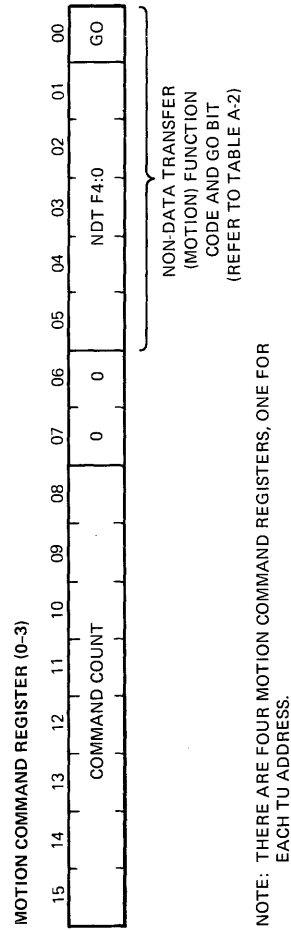

MA-7942

Figure A-8 Motion Command Register

1.10 RELATED DOCUMENTS

The following list describes documents related to the TU78 subsystem.

Title	Document Number	Contents
TM78 Magnetic Tape Formatter User's Guide	EK-0TM78-UG	Description, programming, and installation information of the TM78
TM78 Magnetic Tape Formatter Technical Manual	EK-0TM78-TM	Theory of operation, programming information, installation, and maintenance of the TM78 Formatter and H7422 Power Supply
TU78 Magnetic Tape Transport User's Guide	EK-0TU78-UG	Description, installation instructions, and operating procedures for the TU78.
TU78 Magnetic Tape Transport Technical Manual; Volume 1	EK-1TU78-TM	Schematics and logic prints of TU78
TU78 Magnetic Tape Transport Technical Manual; Volume 2	EK-2TU78-TM	Description, installation, operation, theory, and maintenance of TU78

Title	Document Number	Contents
TU78 Magnetic Tape Transport IPB	EK-TU78-IP	Exploded views and parts lists of TU78 and TM78
874 Power Controller IPB	EK-00874-IP	Exploded views and parts lists of 874
RH20 MASSBUS Controller Unit Description	EK-RH20-UD	Description of RH20 MASSBUS controller
RH780 MASSBUS Adapter Technical Description	EK-RH780-TD	Programming and theory of RH780 MASSBUS adapter
Field Maintenance Print Set	MP01061	Engineering drawings for TU78 mechanics and cabinet, engineering drawings and parts lists for TM78 mechanics and logic, TM78 power supply chassis, +5 volt regulator, ±15 volt regulator, and -5 volt regulator

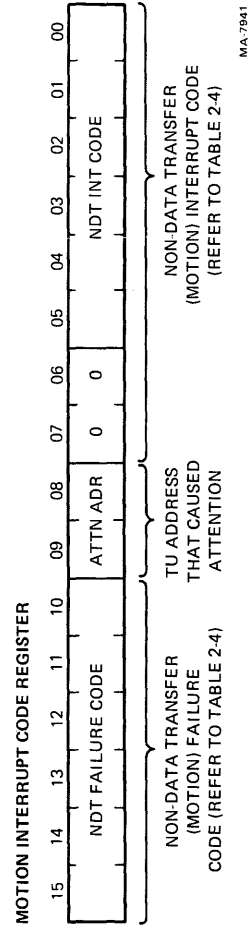
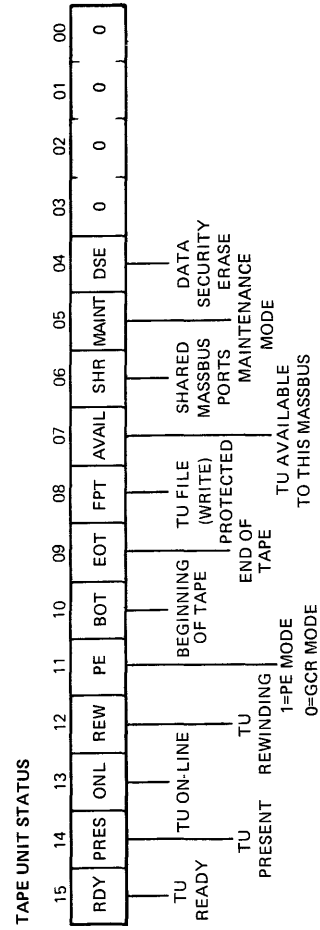

Figure A-7 Motion Interrupt Code Register



MA-7939

Figure A-6 Tape Unit Status Register

1.11 SYSTEM DIAGNOSTICS

The following are system diagnostics for both the TU78 and TM78.

		Diagnostic Name	
	Title	DECSYSTEM-20	VAX
A.	Control Logic Test	DFTUI	EVMAE
B.	Data Reliability	DFTUJ	EVMAA

2 TROUBLESHOOTING

2.1 INTRODUCTION

This chapter gives a short description of the tools available for troubleshooting a failure in the subsystem. They include troubleshooting flows, on-line and in-line diagnostic programs, error log summaries, status indicators, and a maintenance panel for exercising the formatter/transport off-line.

2.2 ON-LINE DIAGNOSTICS

Table 2-1 lists and describes the on-line (system level) diagnostics available for each hardware family.

2.3 IN-LINE DIAGNOSTICS

A total of 37 in-line microdiagnostics run continuously when the subsystem is idle. If a microdiagnostic fails to operate correctly, the TM78 raises an attention interrupt to the host CPU(s). Each microdiagnostic may be called up individually for scope loops or repair verification. This is done through the TM78 maintenance panel. Table 2-2 lists each microdiagnostic and its test number.

2.4 ERROR LOGS

All DEC operating systems, under which the TU78 runs, support an error logging scheme. At a minimum, all MASSBUS registers are read and stored away each time a hard or uncorrectable error occurs. MASSBUS registers are listed in Appendix A. As an error log option, the extended sense summary may also be read and stored away. The extended sense summary is a 60-byte field of internal TM78 and TU78 registers. Extended sense tables for each of four possible TU78s are updated after each error. The extended sense bytes are listed in Appendix B.

2.5 STATUS INDICATORS FOR TROUBLESHOOTING

In addition to the TM78 maintenance panel, a total of 29 LED indicators are available for troubleshooting. Table 2-3 lists each indicator, its function, and location.

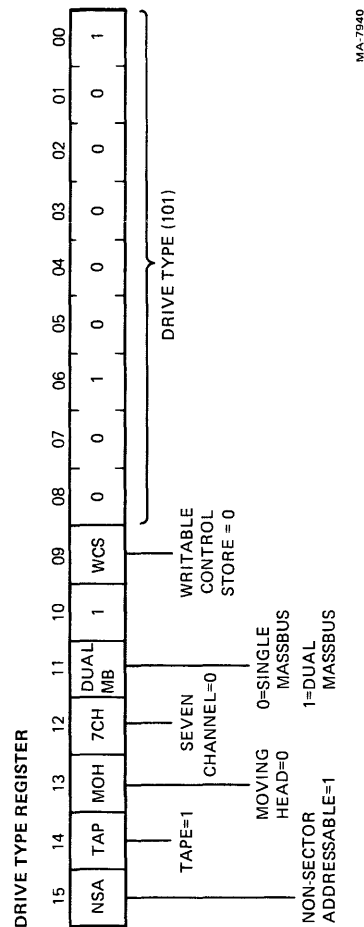

Figure A-5 Drive Type Register

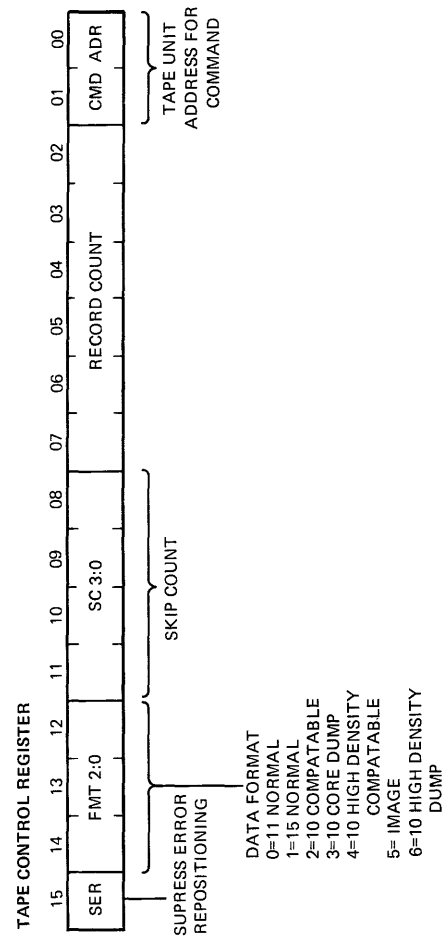

Figure A-4 Tape Control Register

Table 2-1 TM78/TU78 Diagnostics

DECSYSTEM-20	VAX	Description
Control Logic Test		
DFTUI	EVMAE	The Control Logic Test tests MASSBUS controller and TM78 formatter logic. It also tests subsystem basic command functions while checking for proper tape motion timing. The test must be run from each CPU separately, through both MASSBUS ports (if dual port option is present). The test provides error information to the user via console or lineprinter.
Data Reliability		
DFTUJ	EVMAA	The Data Reliability Test tests TM78 circuitry by writing and reading pre-determined data patterns and recording modes. The test provides error information to the user via console or lineprinter. The test may be run in dual port mode (from dual CPUs) driving two or more transports.

2.6 ERROR CODES

The TM78 sends an interrupt code and a failure code to the host CPU at the completion of any command. These same codes are put into the maintenance display at the completion of a command issued through the maintenance keypad. Table 2-4 lists each interrupt code in numerical order followed by each failure code that could occur within that interrupt code.

Note that certain interrupt codes imply that the command completed without error or a nondata record was found (codes 01-06). Others indicate that the transport was not in the correct state to operate on the command, or that another command is necessary (codes 07-27). Still others indicate a possible hardware or software failure (codes 30-32). Interrupt code 77 is a unique code in that it applies only to keypad commands.

Table 2-2 In-Line Self-Test Microdiagnostics

Test Number	Description
0	Write microcontroller self-test (M8959)
1	Translator ROM parity test (M8958)
2	Read path microcontroller self-test (M8953)
3	Read channel 0 (slot AB12) self-test
4	Read channel 1 (slot AB13) self-test
5	Read channel 2 (slot AB14) self-test
6	Read channel 3 (slot AB15) self-test
7	Read channel 4 (slot AB16) self-test
10	Read channel 5 (slot CD13) self-test
11	Read channel 6 (slot CD14) self-test
12	Read channel 7 (slot CD15) self-test
13	Read channel P (slot CD16) self-test
14	Read path error corection self-test (M8951)
15	Microcomputer RAM memory self-test (Loc 40000-40777)
16	Microcomputer RAM memory self-test (Loc 41000-41777)
17	Microcomputer RAM memory self-test (Loc 42000-42777)
20	Microcomputer RAM memory self-test (Loc 43000-43777)
21	Microcomputer RAM memory self-test (Loc 44000-44777)
22	Microcomputer RAM memory self-test (Loc 45000-45777)
23	Microcomputer RAM memory self-test (Loc 46000-46777)
24	Microcomputer RAM memory self-test (Loc 47000-47777)
25	Loop write-to-read at TU port 0 in GCR
26	Loop write-to-read at TU port 0 in PE
27	Loop write-to-read at TU port 1 in GCR
30	Loop write-to-read at TU port 1 in PE
31	Loop write-to-read at TU port 2 in GCR
32	Loop write-to-read at TU port 2 in PE
33	Loop write-to-read at TU port 3 in GCR
34	Loop write-to-read at TU port 3 in PE
35	Loop write-to-read at MIA 0 in GCR
36	Loop write-to-read at MIA 0 in PE
37	Loop write-to-read at MIA 1 in GCR
40	Loop write-to-read at MIA 1 in PE
41	Loop write-to-read at MIA 2 in GCR
42	Loop write-to-read at MIA 2 in PE
43	Loop write-to-read at MIA 3 in GCR
44	Loop write-to-read at MIA 3 in PE

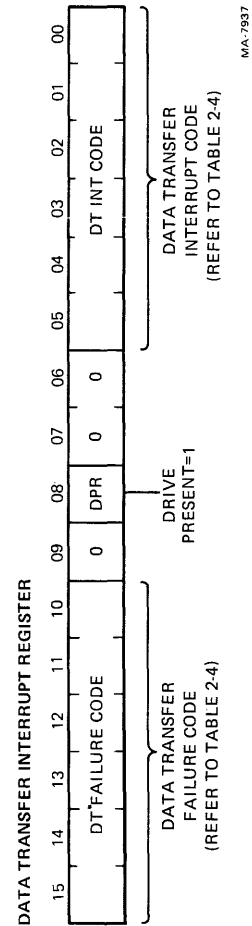

Figure A-3 Data Transfer Interrupt Register

Table A-1 Data Transfer Function Codes

Function Code (Go Bit Included)	Name	Description
51	WRT CK FWD	Write Check Forward – Tape subsystem reads one record in a forward direction. Data is checked in RH controller.
57	WRT CK REV	Write Check Reverse – Tape subsystem reads one record in a reverse direction. Data is checked in RH controller.
61	WRITE PE*	Write phase-encoded records
63	WRITE GCR*	Write group-coded records
71	READ FWD	Read records forward
73	EXSNS	Read extended sense error log
77	READ REV	Read records reverse

*The recording density format is ignored unless the tape is positioned at load point. At load point, the write command specifies the recording format of the entire tape.

Table 2-3 Troubleshooting Indicator Functions

Indicator Number on Figure	Function	Possible Failing FRU
1-3 1*	A channel has failed. These nine indicators reflect the quality of the data stream for each channel or track. They indicate loss of SYNC or track dropout. Nonlatched	<ul style="list-style-type: none"> • TU78 transport • TU Bus cable (n)B • M8950
1-3 2*	A parity error has occurred in the ECC microcontroller. Latched	<ul style="list-style-type: none"> • M8951
1-3 3*	There has been a TU bus status parity error. Wrong Parity was received at the TU port on the WCS lines. Latched	<ul style="list-style-type: none"> • TU bus cable (n)A • TU78 MIA • M8955
1-3 4*	– 5 V for the MASSBUS transceivers is out of specification. Nonlatched	<ul style="list-style-type: none"> • H7490 • H7422 • TM78 backplane
1-3 5*	Wrong parity was received at the MASSBUS port on a control bus command write. Latched	<ul style="list-style-type: none"> • MASSBUS cable • RHXX controller • M8957
1-3 6*	A parity error has occurred in the translator microcontroller. Latched	<ul style="list-style-type: none"> • M8958
1-3 7*	A parity error has occurred in the write microcontroller. Latched	<ul style="list-style-type: none"> • M8959

*The normal state of the indicator is off.

Table 2-3 Troubleshooting Indicator Functions (Cont)

Indicator Number on Figure	Function	Possible Failing FRU
1-3 8*	A parity error has occurred in the microcomputer program ROM. Latched	<ul style="list-style-type: none"> M8960
1-8 9†	+5 V regulator 2 is ok (supplies TM78 read path).	<ul style="list-style-type: none"> H7441 Any module in slots 10<16
1-8 10†	+5 V regulator 4 is ok (supplies TM78 write path, MASSBUS ports TU ports and micro-computer.	<ul style="list-style-type: none"> H7441 Any module in slots 1<9
1-8 11†	-5 V regulator 1 is ok.	<ul style="list-style-type: none"> H7490 M8956 (slot 1 or 3) M8957 (slot 2 or 4)
1-8 12†	+15 V regulator 3 is ok.	<ul style="list-style-type: none"> H7476 Any M8950
1-8 13†	-15 V regulator 3 is ok.	<ul style="list-style-type: none"> H7476 Any M8950
1-8 14†	Power is being applied to the H7422 power supply.	<ul style="list-style-type: none"> H7422 circuit breaker tripped H7422 power cord H7422 supply
1-6 15†	A command or command address on the WCS lines was received at the MIA with wrong parity.	<ul style="list-style-type: none"> TU bus cable (n)A M8955 TU78 MIA
1-6 16†	MIA PCBA maintenance switch S4 is in MANUAL position.	<ul style="list-style-type: none"> Flip switch to AUTO

*The normal state of the indicator is off.

†The normal state of the indicator is on.

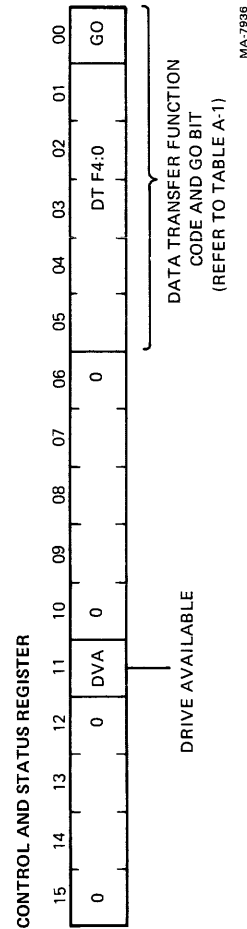

Figure A-2 Control and Status Register

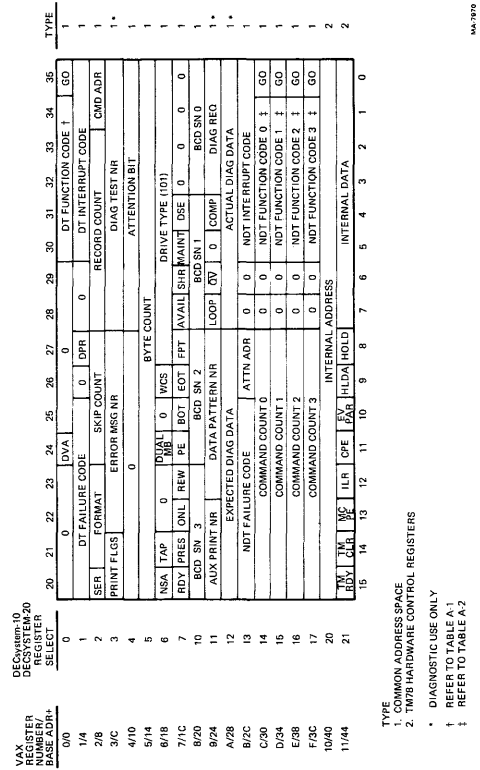

Figure A-1 RH20 and RH780 Addresses

Table 2-4 Interrupt Code to Failure Code

Int Code	Name	Failure Code
01	DONE*	00 – Extended sense data not updated
		01 – Extended sense data updated and contains something of interest
02	TAPE MARK*	Always zero
03	BOT*	01 – Command was issued with tape at BOT
		02 – Saw BOT indicator after tape motion started
		03 – ARA ID detected
04	EOT*	00 – Extended sense data not updated
		01 – Extended sense data updated and contains something of interest
05	LOGICAL EOT†	Always zero
06	NO OP†	Always zero
07	REWINDING†	Always zero
10	FPT*	Always zero
11	NOT READY*	01 – TU is on-line but not ready (Possible when TU is manually rewound or loading)
		02 – Fatal error has occurred and this command cannot be performed until error status has been presented and a TM CLEAR received

*The interrupt code is used for nondata transfer or data transfer.

†The interrupt code is used for nondata transfer only.

Table 2-4 Interrupt Code to Failure Code (Cont)

Int Code	Name	Failure Code
		03 – Access to TU is allowed but TU is either rewinding or doing a DSE from another MASSBUS or keypad command
12	NOT AVAIL*	Always zero
13	OFF LINE*	Always zero
14	NOT EXECUTABLE*	Always zero
15	NOT CAPABLE*	01 – No record found within 25 ft (7.6 m) of tape
		02 – ID burst neither PE or GCR
		03 – ARA ID not found
		04 – No GAP found after ID burst (PE) or ARA ID burst (GCR)
17	ON LINE‡	Always zero
20	LONG REC§	00 – Extended sense data not updated
		01 – Extended sense data updated and contains something of interest
21	SHORT REC§	00 – Extended sense data not updated
		01 – Extended sense data updated and contains something of interest
22	RETRY §	01 – CRC error, ACRC error, pointer mismatch, uncorrectable or two-track error set in ECCSTA register (This code generated by write GCR operations)

APPENDIX A SUBSYSTEM MASSBUS REGISTERS

Table 3-3 Vacuum and Pressure Valve Components

Reference	Description
A	System vacuum test point
B	Reel motor connections
C	Butterfly valve adjustment screw
D	Takeup reel vacuum adjustment screw
E	Vacuum present switch
F	Takeup reel vacuum port
G	Tape on reel switch
H	Vacuum input (to pneumatic assembly)
I	Butterfly valve lock nut
J	Air bearing pressure adjustment screw
K	Pressure input (to pneumatic assembly)
L	Thread block pressure adjustment screw
M	Thread block pressure port
N	Air bearing pressure port

Table 2-4 Interrupt Code to Failure Code (Cont)

Int Code	Name	Failure Code
02		CRC error, ACRC error or uncorrectable set in ECCSTA register (This code generated by read GCR operations)
03		Uncorrectable error set in ECCSTA register (This code generated by read PE operations)
04		AMTIE, pointer mismatch, uncorrectable, two-track error or single-track error set in ECCSTA register (This code generated by write PE operations)
05		At least one bit set in ECCSTA register
06		At least one write fail bit set in RPFail and RPATH registers (This code generated by write PE operations)
07		More than one write fail bit set in RPFail and RPATH registers (This code generated by write CR operations)
10		RSTAT contains bad code
11		GCR characters from WMC and RMC do not match (This code generated by write PE operations)

*The interrupt code is used for nondata transfer or data transfer.

†The interrupt code is used for nondata transfer only.

‡The interrupt code is used for TM78 initiated.

§The interrupt code is used for data transfer.

Table 2-4 Interrupt Code to Failure Code (Cont)

Int Code	Name	Failure Code
		12 – MASSBUS data bus parity error (write)
		13 – Record length incorrect during retry opposite attempt; invalid data has been transferred
23	READ OPP§	Same as Int Code 22
24	UNREADABLE §	Same as Int Code 22
25	ERROR §	Same as Int Code 22
26	EOT ERROR §	Same as Int Code 22
27	BAD TAPE*	Same as Int Code 22
30	TM FAULT A*	01 – Illegal command code
		02 – Data transfer command issued while nondata transfer command in progress on same tape unit
		03 – WMC error; check ECODE register for reason – may be Illegal Format or Skip Count codes
		04 – RUN not received from MASSBUS controller
		05 – Command read from RMC register RCMLP did match command loaded into RCMD register
		06 – ECC ROM parity error (M8951)
		07 – XMC ROM parity error (M8958)

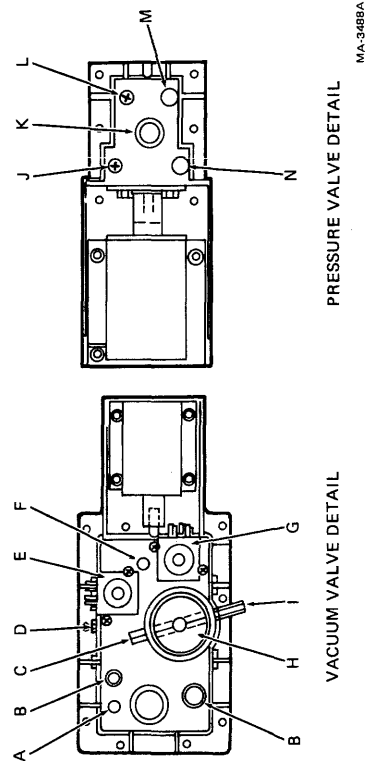

Figure 3-4 Vacuum Valve and Pressure Valve

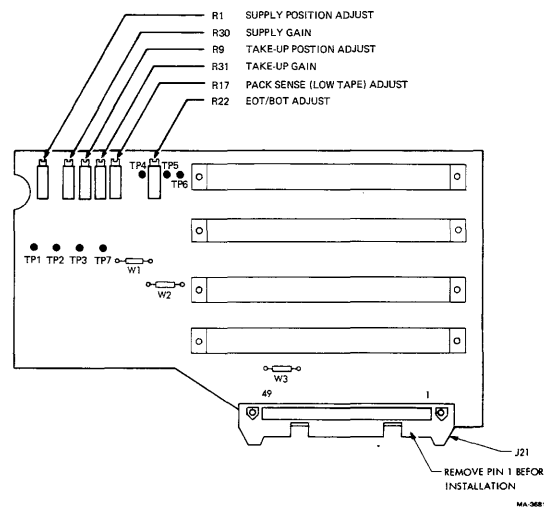

Figure 3-3 Interconnect F1 PCBA
b. Current Model

Table 2-4 Interrupt Code to Failure Code (Cont)

Int Code	Name	Failure Code
10	Command read from RMC register RCMLP did not match command loaded into RCMD register (this code generated when Verify ID Burst command loaded during write of BOT area)	
11	Command read from RMC register RCMLP did not match command loaded into RCMD register (this code generated when Verify ARA Burst command loaded during write of BOT area)	
12	Command read from RMC register RCMDP did not match command loaded into RCMD register (this code generated when Verify ARA ID command loaded during write of BOT area)	
13	Command read from RMC register RCMLP did not match command loaded into RCMD register (this code generated when Verify Gap command loaded during write BOT area)	

*The interrupt code is used for nondata transfer or data transfer.

†The interrupt code is used for nondata transfer only.

‡The interrupt code is used for TM78 initiated.

§The interrupt code is used for data transfer.

Table 2-4 Interrupt Code to Failure Code (Cont)

Int Code	Name	Failure Code
14	Command read from RMC register RCMLP did not match command loaded into RCMD register (this code generated when Read ID Burst command loaded during read of BOT area)	
15	Command read from RMC register RCMLP did not match command loaded into RCMD register (this code generated when Verify ARA ID command loaded during read of BOT area)	
16	Command read from RMC register RCMLP did not match command loaded into RCMD register (this code generated when Verify Gap command loaded during read of BOT area)	
17	Command read from RMC register RCMLP did not match command loaded into RCMD register (this code generated when Find Gap command loaded during Erase Gap routine)	
20	WMC LEFT failed to set in Extended Sense routine	
21	PE WRITE PE set in INTSTA register (M8958)	

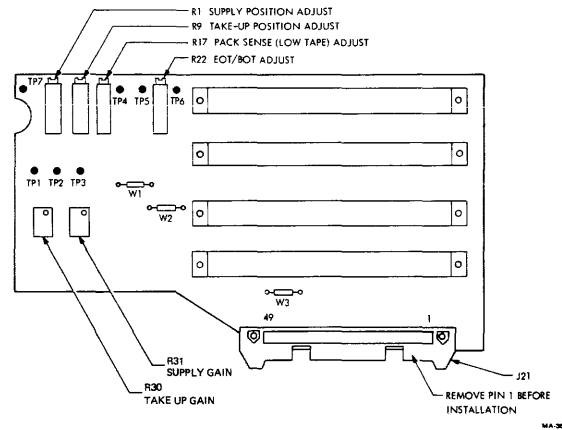

**Figure 3-3 Interconnect F1 PCBA
a. Early Model**

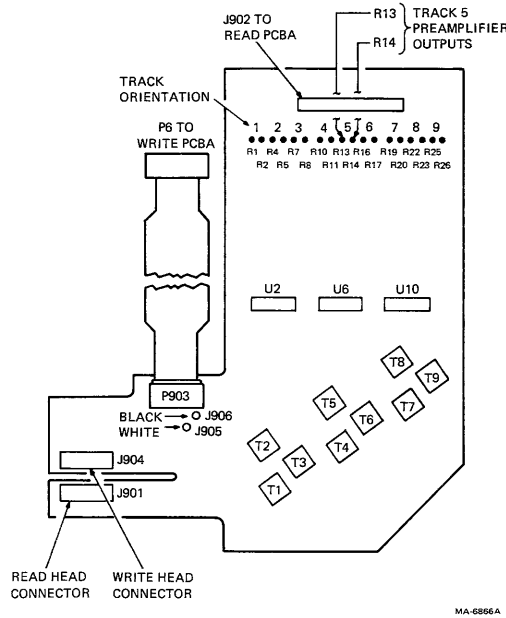

Figure 3-2 GCR/PE Preamp 1 PCBA Test Points

Table 2-4 Interrupt Code to Failure Code (Cont)

Int Code	Name	Failure Code
		22 – XMC DONE did not set (M8958, M8959)
		23 – WMC ROM PE or RD PE set in WMCERR register (M8959, M8952, M8951)
31	TU FAULT A*	01 – TU status parity error (MIA)
		02 – TU command parity error (M8955)
		03 – Rewinding tape went off-line
		04 – Tape went not ready during DSE
		05 – TU CMD status changed during DSE
		06 – TU velocity never came up to speed
		07 – TU velocity changed after up to speed and writing started
		10 – TU CMD did not load correctly to start tape motion in selected function routine
		11 – TU CMD did not load correctly to set drive density
		12 – TU CMD did not load correctly to start tape motion to write BOT ID Burst

*The interrupt code is used for nondata transfer or data transfer.

Table 2-4 Interrupt Code to Failure Code (Cont)

Int Code	Name	Failure Code
13	TU CMD did not load correctly to backup tape to BOT after failing to write BOT ID	
14	Failed to write density ID Burst correctly	
15	Failed to write ARA Burst correctly	
16	Failed to write ARA ID correctly	
17	ARA error bit set in MTA status B register	
21	Could not find a gap after the ID code was written correctly	
22	TU CMD did not load correctly to start tape motion to read ID Burst	
23	Time-out looking for BOT after detecting ARA ID burst	
24	Failed to write tape mark correctly	
25	Tape never came up to speed while trying to reposition for retry of writing tape mark	
26	TU CMD did not load correctly to start tape motion in Erase Gap routine	
27	Could not detect a gap in Erase Gap routine	
30	Could not detect a gap after writing record	

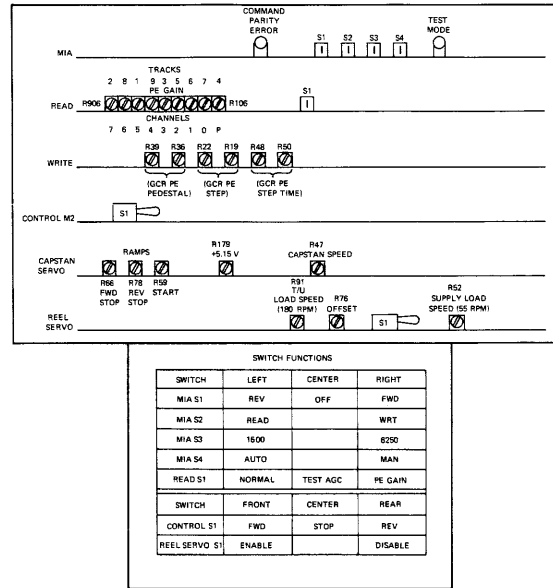

Figure 3-1 TU78 Card Cage Showing Maintenance Switches and Adjustment

Table 3-2 Adjustment Specifications (Cont)

Parameter	Specified Value and Tolerance	Test Point	Adjustment	Adjustment Paragraph
TM78 Power +5 V (read path)	+5 Vdc, ± 0.1 Vdc	A16A2	A7422 Regulator 2	TM78 Tech Manual Table 5-10
+5 V (write path and control)	+5 Vdc, ± 0.1 Vdc	A09A2	H7422 Regulator 4	Table 5-10
-5 V	-5.0 Vdc, $\pm .16$ Vdc	A01V2	H7422 Regulator 1	Table 5-10

Table 2-4 Interrupt Code to Failure Code (Cont)

Int Code	Name	Failure Code
		31 - Read path terminated before entire record was written
		32 - Could not find a gap after writing record and read path terminated early
		33 - TU CMD did not load correctly to backup for retry of write tape mark
		34 - TU velocity changed after up to speed while trying to reposition for retry of writing tape mark
		35 - TU CMD did not load correctly to backup to retry a read of BOT ID
		36 - Time-out looking for BOT after failing to write BOT ID
		37 - TU velocity changed while writing PE gap before starting to write record
		40 - TU CMD did not load correctly to set PE tape density at start of write BOT ID burst
		41 - TU CMD did not load correctly to set GCR tape density after writing Density ID
		42 - TU CMD did not load correctly to set PE tape density at start of read from BOT

Table 2-4 Interrupt Code to Failure Code (Cont)

Int Code	Name	Failure Code
		43 - TU CMD did not load correctly to set GCR tape density after reading a GCR Density ID burst
32	TM FAULT B‡	00 - RST0 interrupt occurred with TM RDY still set (AC/DC LO)
		01 - Power failed interrupt
		02 - Interrupt for unknown reason on channel 5.5
		03 - Interrupt for unknown reason on channel 6.5
		04 - Interrupt for unknown reason on channel 7
		05 - Interrupt for unknown reason on channel 7.5
		06 - CAS contention retry count expired
		07 - CAS contention error not retryable
		10 - Queue error; could not find queue entry
		11 - Queue entry already full
		12 - 8085 ROM parity error
		13 - In-line test 0; WMC self test failed = M8959-M8957
		14 - In-line test 1; XMC ROM parity error M8958-M8959-M8960
		15 - In-line test 2; RPM self-test failed M8953-M8960

Table 3-2 Adjustment Specifications (Cont)

Parameter	Specified Value and Tolerance	Test Point	Adjustment	Adjustment Paragraph
Skew (azimuth)	Leading step width (using skew tape) = 1.2 μs maximum, Adjust for minimum	Read PCBA TP11	Head azimuth screw	6.5.7.1
Write current	Refer to procedure in TM	-	-	6.5.7.2
PE gain	1.25 V PP at Preamp output resistor writing all 1s on a standard output tape	Preamp resistor upper lead R1 R4 R7 R10 R13 R16 R19 R22 R25	Read PCBA Potentiometer R706 R906 R506 R106 R406 R306 R206 R806 R606	6.5.7.3

Table 3-2 Adjustment Specifications (Cont)

Parameter	Specified Value and Tolerance	Test Point	Adjustment	Adjustment Paragraph
Supply reel load speed	55 rpm (± 5 rpm) Reel servo PCBA TP60 and TP69 to ground (TP49)	—	Reel servo PCBA R52	6.5.6.2
Takeup reel load speed	180 rpm (± 18 rpm) Reel servo PCBA TP60 and TP57 to ground (TP49)	—	Reel servo PCBA R91	6.5.6.3
Tape loop position	Refer to procedure in TM	—	—	6.5.6.4
Read/Write	Clean tape path	—	—	4.3.4

Table 2-4 Interrupt Code to Failure Code (Cont)

Int Code	Name	Failure Code
16	—	In-line test 3; RPM1 channel 0 self-test failure M8950 (slot AB12)
17	—	In-line test 4; RPM1 channel 1 self-test failure M8950 (slot AB13)
20	—	In-line test 5; RPM1 channel 2 self-test failure M8950 (slot AB14)
21	—	In-line test 6; RPM1 channel 3 self-test failure M8950 (slot AB15)
22	—	In-line test 7; RPM1 channel 4 self-test failure M8950 (slot AB16)
23	—	In-line test 10; RPM1 channel 5 self-test failure M8950 (slot CD13)
24	—	In-line test 11; RPM1 channel 6 self-test failure M8950 (slot CD14)
25	—	In-line test 12; RPM1 channel 7 self-test failure M8950 (slot CD15)
26	—	In-line test 13; RPM1 channel P self-test failure M8950 (slot CD16)
27	—	In-line test 14; RPM1 error correction self-test M8950-M8951-M8953
30	—	In-line test 15; 40000 – 40777 RAM memory failure M8960

‡The interrupt code is used for TM78 initiated.

§The interrupt code is used for data transfer.

Table 2-4 Interrupt Code to Failure Code (Cont)

Int Code	Name	Failure Code
31	In-line test 16; 41000	41777 RAM memory failure M8960
32	In-line test 17; 42000	42777 RAM memory failure M8960
33	In-line test 20; 43000	43777 RAM memory failure M8960
34	In-line test 21; 44000	44777 RAM memory failure M8960
35	In-line test 22; 45000	45777 RAM memory failure M8960
36	In-line test 23; 46000	46777 RAM memory failure M8960
37	In-line test 24; 47000	47777 RAM memory failure M8960
40	In-line test 25; loop write-to-read at TU port 0 - GCR	
41	In-line test 26; loop write-to-read at TU port 0 - PE	
42	In-line test 27; loop write-to-read at TU port 1 - GCR	
43	In-line test 30; loop write-to-read at TU port 1 - PE	
44	In-line test 31; loop write-to-read at TU port 2 - GCR	

Table 3-2 Adjustment Specifications (Cont)

Parameter	Specified Value and Tolerance	Test Point	Adjustment	Adjustment Paragraph
Forward stop ramp	Use TM78 maintenance panel Keypad OP code = 36 (REP) Display value = L 00	-	Capstan/regulator, R66	6.5.5
Reverse stop ramp	Use TM78 maintenance panel Keypad OP code = 40 (REP) Display value = L 00	-	Capstan/regulator, R78	6.5.5
Reel Servo Servo offset	No rotation of supply reel hub	-	Reel servo PCBA R76	6.5.6.1

Table 3-2 Adjustment Specifications (Cont)

Parameter	Specified Value and Tolerance	Test Point	Adjustment	Adjustment Paragraph
Cartridge pressure	2.5 inches of water (± 0.5 inches of water)	Cartridge pressure port	Cartridge pressure screw	6.5.4.4
Capstan Servo Tape speed	Use TM78 maintenance panel Keypad OP code = 32 (REP) Display value = L 00	-	Capstan/regulator, R47	6.5.5
Forward start ramp	Use TM78 maintenance panel Keypad OP code = 34 (REP) Display value = L 00	-	Capstan/regulator, R59	6.5.5

Table 2-4 Interrupt Code to Failure Code (Cont)

Int Code	Name	Failure Code
45	-	In-line test 32; loop write-to-read at TU port 2 - PE
46	-	In-line test 33; loop write-to-read at TU port 3 - GCR
47	-	In-line test 34; loop write-to-read at TU port 3 - PE
50	-	In-line test 35; loop write-to-read at MTA 0 - GCR
51	-	In-line test 36; loop write-to-read at MTA 0 - PE
52	-	In-line test 37; loop write-to-read at MTA 1 - GCR
53	-	In-line test 40; loop write-to-read at MTA 1 - PE
54	-	In-line test 41; loop write-to-read at MTA 2 - GCR
55	-	In-line test 42; loop write-to-read at MTA 2 - PE
56	-	In-line test 43; loop write-to-read at MTA 3 - GCR
57	-	In-line test 44; loop write-to-read at MTA 3 - PE

Table 2-4 Interrupt Code to Failure Code (Cont)

Int Code	Name	Failure Code
34	MB FAULT	01 - Control bus parity error (Write)
		02 - Illegal MASSBUS register referenced
77	KEY FAIL	01 - Keypad entry error
		02 - TM78 not off-line
		03 - Illegal instruction code

2.7 TM78 MAINTENANCE PANEL

A firmware driven TM78 maintenance panel provides access to the operational microcode functions, internal hardware registers, and the resident microdiagnostics.

A table of instructions may be created in RAM through the keypad to exercise the formatter or a single tape transport. Many functions of the maintenance panel can be used while the TM78 is on-line and performing tape operations for a host CPU. Added maintenance functions are provided when the TM78 is switched off-line from the host.

NOTE

Because the operational microcode must time-share or interleave the host commands and the maintenance commands, use of the keypad while on-line causes slower response time to the commands issued by the host. Therefore, be sure to check with the system operator before using the maintenance panel to see if this latency is acceptable. If not, use the instruction delay in parameter item No. 2 (Table 2-6).

The maintenance panel includes a 20-key keypad and a 6-digit octal display cluster. Figure 2-1 shows a detailed view of the maintenance panel.

2.7.1 Keypad Function Summary

The following is a summary of the keypad functions.

Table 3-2 Adjustment Specifications (Cont)

Parameter	Specified Value and Tolerance	Test Point	Adjustment	Adjustment Paragraph
Vacuum/Air Pressure System vacuum	34 inches of water with tape running forward (± 1 inch water)	Cripple reel port	Butterfly valve	6.5.4.1
Takeup reel vacuum	19 inches of water (± 1 inch water)	Takeup reel vacuum port	Vacuum valve Friction plate	6.5.4.2
Air bearing pressure	3.75 PSI (± 0.25 PSI) with tape running forward	Air bearing pressure port	Pressure Valve ABP screw	6.5.4.3
Thread block pressure	24 inches of water (± 2 inches of water)	Thread block pressure port	Thread block pressure adjustment screw	6.5.4.4

Table 3-2 Adjustment Specifications

Parameter	Specified Value and Tolerance	Test Point	Adjustment	Adjustment Paragraph
TU78 Supply Voltage +5 V	+5.15 Vdc, ±0.15 Vdc	Capstan/ regulator, TP11	Capstan/ regulator, R179	6.5.1
Tape Path Sensors EOT/BOT sensor	0 Vdc, ±0.1 Vdc with EOT/BOT not under sensor	Interconnect F1, TP6(+) TP5(-)	Interconnect F1, R22	6.5.2
Pack sense	0.5 Vdc max with takeup reel sensor tab in line with sensor	Interconnect F1, TP4(+) TP7(-)	Interconnect F1, R17	6.5.3

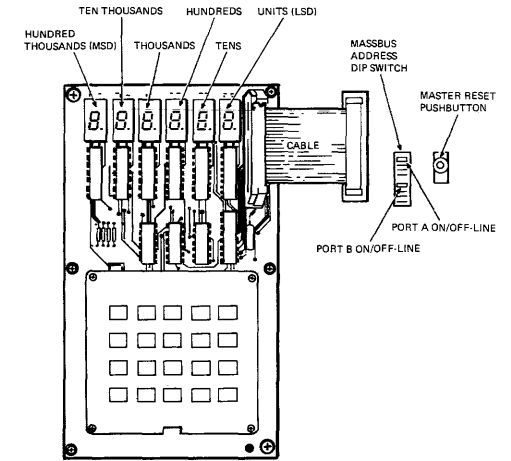

Figure 2-1 TM78 Maintenance Panel

Miscellaneous Keys

ENA Pressing this key once enables the keypad. Pressing this key again disables the keypad.

CLR CLEAR erases a number in the display and stops a looping command.

Numeric Keys

0 → 7 The eight numeric keys specify one of the following before a control or operation key is pressed.

- Memory address
- Memory data
- Internal I/O hardware address
- Internal I/O hardware data
- Parameter item number
- Parameter data
- Instruction item number
- Instruction op-code

Control Keys

INS The INSTRUCTION key is used to examine and modify any of the sixteen instruction locations.

HDW The HARDWARE key is used to examine and modify most of the 377 TM78 internal I/O registers. (Appendix B of the *TM78 Technical Manual*.)

PAR The PARAMETER key is used to examine and modify the set of parameter items that control the microcode in performing maintenance functions.

MEM The MEMORY key is used to examine and modify locations within the microcomputers memory space.

NXT The NEXT key causes the next sequential item or location of the group (**INS**, **HDW**, **PAR**, or **MEM**) selected last to be examined.

DEP The DEPOSIT key is used to modify the contents of an item or location.

Operation Keys

EXE The EXECUTE key is used to execute a single maintenance instruction one time only.

REP The REPEAT key causes a single maintenance instruction code to be executed repeatedly.

STA The START key initiates the execution of instructions previously deposited into the instruction item group.

Table 3-1 Checks/Adjustments When Replacing Parts (Cont)

Part Replaced	Check or Adjustment	Paragraph
Maintenance panel	Keypad/display power on checks	3.5.1.1*
H7441	+5 V	5.7.5†
H7446	±15 V	5.7.5†
H7490	-5 V	5.7.5†

NOTE

The paragraph number listed is for the full procedure found in the applicable technical manual.

*TU78 Technical Manual (Vol II)

†TM78 Technical Manual

Table 3-1 Checks/Adjustments When Replacing Parts (Cont)

Part Replaced	Check or Adjustment	Paragraph
Takeup reel motor	Takeup reel load speed	6.5.6.3*
	Tape loop position	6.5.6.4*
AC motor	Vacuum/pressure	6.5.4*
Blower	System vacuum	6.5.4.1*
	Takeup reel vacuum	6.5.4.2*
Compressor	Air bearing pressure	6.5.4.3*
	Thread block and cartridge pressure	6.5.4.4*
Read PCBA	PE gain	6.5.7.3*
Write PCBA	Write currents	6.5.7.2*
	PE gain	6.5.7.3*
Capstan Servo PCBA	Power Capstan	6.5.1*
	servo adjustments	6.5.5*
Reel servo PCBA	PE gain	6.5.7.3*
	Reel servo adjustments	6.5.6*
Preamp PCBA	Dynamic brake check	6.6.6.1*
	PE gain	6.5.7.3*
Inter-connect F1 PCBA	EOT/BOT sensor	6.5.2*
	Pack sense sensor	6.5.3*
	Tape loop position	6.5.6.4*

CON

The CONTINUE key may be used to continue the maintenance instruction program at the item number saved when it was last stopped.

2.7.2 Errors

An error code is displayed whenever a command cannot be performed. Table 2-5 lists all the error codes and the reason for the error.

Table 2-5 Keypad Error/Status Codes

Code in Display	Meaning
E 001	Value of item number or location is too large for this group.
E 002	Value of item number or location is already at high limit when NXT key was pressed.
E 003	No numeric value was specified before deposit.
E 004	Privileged function is requested (such as modifying a RAM or hardware location) with TM78 on-line.
E 005	ROM address is not in use.
E 006	Illegal instruction code is selected for an instruction item.
77 - 01	Error is detected when attempting to execute a maintenance instruction to a TU78. Either the TU78 selected by parameter item 0 is not in maintenance mode (port select 3), or the adjustment selected is out of acceptable tolerance.
77 - 02	Privileged maintenance instruction is requested with TM78 on-line.
77 - 03	Illegal instruction code is specified when using EXE or REP keys.

2.7.3 Parameters

Table 2-6 lists each parameter location and a description of how it conditions or affects the hardware when running maintenance panel instructions.

Table 2-6 Parameter Items

Item Number	Read/Write	Initialized Value	Description																					
0	R/W	000	<p>MASSBUS Port/Tape unit port select</p> <p>This item selects one of two MASSBUS ports and one of four Tape unit ports to communicate with.</p> <table border="1"> <thead> <tr> <th>Bit</th> <th>Value</th> <th>Port Selected</th> </tr> </thead> <tbody> <tr> <td>7</td> <td>0</td> <td>MASSBUS A</td> </tr> <tr> <td>7</td> <td>1</td> <td>MASSBUS B</td> </tr> <tr> <td>1:0</td> <td>0</td> <td>TU Port 0</td> </tr> <tr> <td>1:0</td> <td>1</td> <td>TU Port 1</td> </tr> <tr> <td>1:0</td> <td>2</td> <td>TU Port 2</td> </tr> <tr> <td>1:0</td> <td>3</td> <td>TU Port 3</td> </tr> </tbody> </table> <p>This item corresponds to hardware register 340-W.</p>	Bit	Value	Port Selected	7	0	MASSBUS A	7	1	MASSBUS B	1:0	0	TU Port 0	1:0	1	TU Port 1	1:0	2	TU Port 2	1:0	3	TU Port 3
Bit	Value	Port Selected																						
7	0	MASSBUS A																						
7	1	MASSBUS B																						
1:0	0	TU Port 0																						
1:0	1	TU Port 1																						
1:0	2	TU Port 2																						
1:0	3	TU Port 3																						
1	R/W	000	<p>Program run control</p> <p>This item is used by the STA and CON keys. When this item is any number other than 0, a program can be single-stepped one instruction at a time. When this item is 0 the program can run.</p>																					
2	R/W	000	<p>Instruction delay</p> <p>This item is used to insert a delay between each instruction pass when in LOOP mode. The larger the number the longer the</p>																					

3 CHECKS AND ADJUSTMENTS

3.1 PARTS REPLACEMENT

Table 3-1 lists the corequisite check or adjustment that must be made when replacing certain parts in the subsystem. If a part is not listed in the table, then no corresponding check or adjustment is required.

3.2 QUICK REFERENCE ADJUSTMENT SPECIFICATION

Table 3-2 provides a quick reference to the various TM78/TU78 adjustment specifications. Figure 3-1, 3-2 and 3-3 show the location of various controls and switches on the TU78 PCBAs. Figure 3-4 shows the air valves with their test points and adjustments.

Table 3-1 Checks/Adjustments When Replacing Parts

Part Replaced	Check or Adjustment	Paragraph
Read/write/erase head	Clean transport	4.3.4*
	Power	6.5.1*
	Capstan servo adjustment	6.5.5*
Capstan motor	Read/write adjustments	6.5.7*
	System vacuum	6.5.4.1*
	Takeup reel vacuum	6.5.4.2*
Supply reel motor	Read skew	6.5.7.1*
	Supply reel load speed	6.5.6.2*
	Tape loop position	6.5.6.4*

*TU78 Technical Manual (Vol II)

Interconnect F1 PCBA

TP 1 S POS
 TP 2 T POS 2
 TP 3 TIP
 TP 4 N PKSN
 TP 5 EOT
 TP 6 BOT
 TP 7 GND

Reel Servo PCBA

TP 1
 TP 2
 TP 4 +36 V (T)
 TP 6 TM (+)
 TP 8 TM (-)
 TP10 -36 V (T)
 TP12 +36 V (S)
 TP14 SM (-)
 TP16 SM (+)
 TP18 -36 V (S)
 TP20 UNUSED
 TP21 NTDA
 TP22 NTDB
 TP23 NSDA
 TP24 NSDB
 TP49 GND
 TP50 GND
 TP51 Q2 (COLL)
 TP52 REEL SERVO BRAKE
 TP 53 +5 V (S) TO ALL IC'S
 TP54 UNUSED
 TP55 TPOS
 TP56 NTRRTP57 NTRF
 TP58 SUM AMP OUT NDTA/B
 TP59 SUM AMP OUT T/U LOOP COMP
 TP60 NAE (REEL SERVO ENAB)
 TP61 NTINTLK
 TP62 +15 V DC
 TP63 UNUSED
 TP64 -15 V DC
 TP65 1.25 KHZ T-WAVE GEN
 TP66 SPOS
 TP67 OFFSET
 TP68 SUM AMP OUT SUP LOOP COMP
 TP69 NSRF 1
 TP70 NSRR
 TP71 SUM AMP OUT NSDA/B
 TP72 NSRF 2

Table 2-6 Parameter Items (Cont)

Item Number	Read/Write	Initialized Value	Description
			delay. The delay can be used to reduce the impact on host CPU throughput, to allow tape to stop between instructions, etc.
3	R/W	000	General-Purpose counter This counter can be loaded, counted, and tested by maintenance instructions.
4	R	000	Branch status Status byte returned by all instructions. Used by conditional branch instructions. Bit 0 – error Bit 1 – end of tape Bit 2 – tape mark
5	R	000	Interrupt code (Table 2-5)
6	R	000	Failure code (Table 2-5) Items 5 and 6 contain the execute status returned by the last tape command or in-line diagnostic control instruction. Program control and privileged instructions return execute status but do not write into these parameter items. These items make it possible to run a program that performs tape commands and halts if an error is detected. The actual error can be identified by examining these parameter items after the program halts.

Table 2-6 Parameter Items (Cont)

Item Number	Read/Write	Initialized Value	Description
7	R	000	Program continue address The CON key uses this item to determine next instruction address.
10	R/W	*	In-line diagnostic index This item selects an in-line diagnostic program for maintenance instruction 16. Refer to Table 2-2 for a listing of the in-line tests available.
11	R/W	120	Data format and skip count Data transfer maintenance instructions uses this item and corresponds to hardware register 320-W. Initialized to image format with a zero skip count.
Bit Value Description			
7	-	-	Not used
6:4	-	-	Format Control
	0	11	normal
	1	15	normal
	2	10	compatible
	3	10	core dump
	4	10	high-density compatible
	5	Image (skip count has no effect)	
	6	10	high-density dump
	7	Illegal	

TP21 CLEAR
 TP22 ST1 CLOCKS
 TP23 UNUSED
 TP24 UNUSED

Write PCBA

TP 1 CLK 2
 TP 2 V PED
 TP 3 V STEP
 TP 4 V WRT
 TP 5 CLK 1
 TP 6 V PED AT Q27/28 WD2
 TP 7-23 UNUSED
 TP24 REWR (REWIND RAMP)

Capstan/Regulator PCBA

TP 1 GND
 TP 2 GND
 TP 3-10 UNUSED
 TP11 +5 V DC
 TP12 V SENSE
 TP13 MOTOR CURRENT
 TP14 UNUSED
 TP15 +15 VDC
 TP16 UNUSED
 TP17 UNUSED
 TP18 -15 VDC
 TP19 MOTOR VOLTAGE
 TP20-24 UNUSED
 TP49 CAPSTAN GND
 TP50 CAPSTAN GND
 TP51 NFPT
 TP52 ANALOG TACH
 TP53 UNUSED
 TP54 UNUSED
 TP55 SPARES 1
 TP56 CART SOL RET
 TP57 VAC SOL RET
 TP58 WP SOL RET
 TP59 PRES SOL RET
 TP60-64 UNUSED
 TP65 8.5 VAC
 TP66-69 UNUSED
 TP70 NPORST
 TP71 CART MTR (+)
 TP72 UNUSED

Control M2 PCBA

TP35 – LDF 3
 TP36 – NBOT
 TP37 – STL
 TP38 – NEOT
 TP39 – CLK C (10 KHZ)
 TP40 – TACH AMP
 TP41 – LDF 5
 TP42 – LDF4
 TP43 – LOW TAPE SENSOR
 TP44 – NLDFS
 TP45 – LDS (LOAD FAULT SENSE)
 TP46 – BKW
 TP47 – MRL
 TP48 – ABP N/O
 TP49 – GND
 TP50 – GND
 TP51 – NPOL
 TP53 – THD
 TP54 – CC N/O
 TP55 – CO N/O
 TP56 – U146-5 UNLD
 TP57 – S LIMIT N/O
 TP58 – NSMRL
 TP59 – TOR N/O
 TP60 – VAC N/O
 TP61 – T LIMIT N/O
 TP62 – NINTLK
 TP63 – NCCC (CLOSE CART CMD)
 TP64 – SRF
 TP65 – SRR
 TP66 – TRF
 TP67 – TRR
 TP68 – THDS
 TP69 – NCOC (CART OPEN CMD)
 TP70 – NRS AE (REEL SERVO ENABLE)
 TP71 – PNU RET
 TP72 – NXFR

Read PCBA

TP 1
 TP 2
 TP 3-9 UNUSED
 TP10 TRK 9/0 ACTIVE (CH4 & 6)
 TP11 TRK 9/1 ACTIVE (CH4 & 5)
 TP12-19 UNUSED
 TP20 U29-11

Table 2-6 Parameter Items (Cont)

Item Number	Read/Write	Initialized Value	Description
			3:0 Skip Count
			00 No skip
			01 Skip 1 byte
			02 Skip 2 bytes
			03 Skip 3 bytes
			04 Skip 4 bytes
			05 Skip 5 bytes
			06 Skip 6 bytes
			07 Skip 7 bytes
			10 Skip 8 bytes
			11-17 Illegal
12	R/W	020	Write function clock control
13	R/W	022	Read GCR function clock control
14	R/W	023	Read PE function clock control
15	R/W	020	LOOP write to read function clock control
			Items 12 – 15 are the data loaded into the clock control register before the function is performed. Refer to hardware register 360-W in TM78 Technical Manual for a description of the bit combinations.
16	R/W	005000	Write record size
			This 16-bit item is the byte count used by write data maintenance instructions to determine the size of the record written. It is used by read data maintenance instructions as the expected record size.

*Item value is not initialized by enabling keypad.

Table 2-6 Parameter Items (Cont)

Item Number	Read/Write	Initialized Value	Description
17	R	000000	Read record size This 16-bit item is returned by read data instructions as actual size of record read.
20	R/W	777777	Write data This 18-bit item is written into the DDR for write data instructions.
21	R	000000	Read data This 18-bit item contains the contents of the DDR after the last read data instruction, if performed in image format. It is cleared on every read in all other formats.
22	R	*	Last fatal interrupt code for port A
23	R	*	Last fatal interrupt code for port B Item 23 and 24 are a history of last fatal interrupt code (right justified).
24	R	*	Last fatal failure code for port A
25	R	*	Last fatal failure code for port B Items 23 and 24 are a history of the last fatal failure code (left justified).

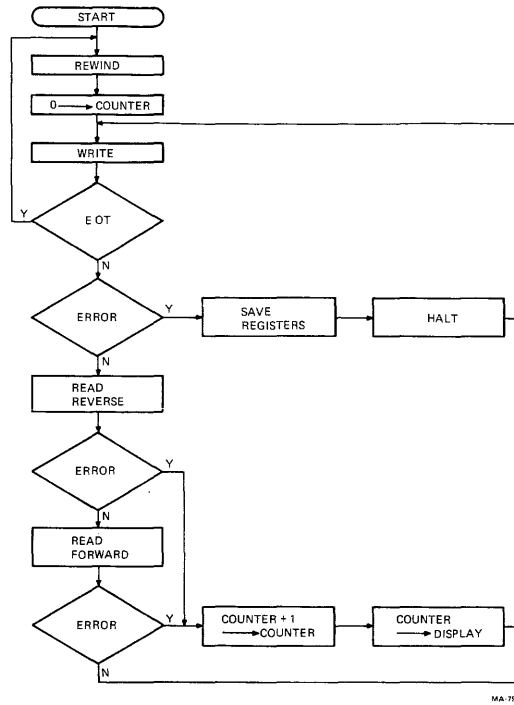

Figure 2-2 Sample Write/Read Routine

Control M2 PCBA

- TP19 - CLK E (10 HZ)
- TP20 - CLK A (1 MHZ)
- TP22 - U71-6 CAPSTAN REV
- TP23 - U63-6
- TP24 - U66-6 NRDY
- TP25 - GND
- TP26 - GND
- TP27 - LDF 1
- TP28 - LDF 6
- TP29 - U72-11 RWS
- TP30 - MAINT FUNCTION
- TP31 - MAINT FUNCTION
- TP32 - LDF 2
- TP33 - NTAP 2
- TP34 - N > 80 %

2.7.5 Sample Maintenance Routine

Figure 2-2 shows the program flow for a sample write/read maintenance routine. This routine writes a record, reads it backward and forward, then repeats the operation till the EOT marker is reached where the tape is rewound. A tally of all read errors is put into the display for each tape pass. If a write error occurs, many important TM78/TU78 registers are saved in parameter locations. Then the program halts so that these parameters can be analyzed.

The program coding is shown below.

Instruction Address	Instruction Code	Description
0	7	Rewind tape
1	100	Clear counter
2	61 (63)	Write PE (GCR)
3	240	If EOT, branch to start
4	214	If error, branch to save
5	77	Read reverse
6	211	If error, branch to count update
7	71	Read forward
10	222	Branch to write if no error
11	4	Increment counter +1
12	12	Put count in display
13	362	Branch to write
14	10	Save registers
15	2	Halt
16	362	Branch to write after continue
17	-	-

2.8 TEST POINTS

The following list includes all troubleshooting test points available on the TU78 PCBAs and the corresponding signal name.

Control M2 PCBA

- TP 1 - GND
- TP 2 - GND
- TP 3-12 - UNUSED
- TP13 - +5 V DC
- TP14 - LDF0
- TP15 - CLK B (100 KHZ)
- TP16 - U85-2
- TP17 - UNUSED
- TP18 - NLDAP1

Table 2-6 Parameter Items (Cont)

Item Number	Read/Write	Initialized Value	Description
The remaining items are stored whenever the execution of a tape unit operation results in an error. The error status in the hardware registers is saved so that it can be interrogated by maintenance personnel. A copy of these items exists for each tape unit and is readable by the host CPU EXT SENSE command.			
26	R	*	Command code is being executed on last error.
27	R	*	Interrupt code is 6 bits right justified.
30	R	*	Failure code is 6 bits right justified.
NOTE Items 26 through 30 are written with zeros when these locations are written as a result of the keypad hardware dump instruction.			
			Items 31 - 105 are hardware registers.
			Register Contents
31	R	*	0 Read path write fail bits
32	R	*	1 Read path diagnostic bits
33	R	*	2 Read path status
34	R	*	3 Read path CMD
35	R	*	20 AMTIE
36	R	*	21 RC done
37	R	*	22 Illegal 5-4/
40	R	*	23 Mark 2
41	R	*	24 End mark
42	R	*	25 RC par bits
43	R	*	26 Postamble det
44	R	*	27 Data
45	R	*	30 CRC
46	R	*	31 Corrected data
47	R	*	32 ECC status
50	R	*	40 Channel 0 TIE bus
51	R	*	41 Channel 1 TIE bus

*Item value is not initialized by enabling keypad.

Table 2-6 Parameter Items (Cont)

Item Number	Read/Write	Initialized Value	Description
Register Contents			
52	R	*	42 Channel 2 TIE bus
53	R	*	43 Channel 3 TIE bus
54	R	*	44 Channel 4 TIE bus
55	R	*	45 Channel 5 TIE bus
56	R	*	46 Channel 6 TIE bus
57	R	*	47 Channel 7 TIE bus
60	R	*	50 Channel P TIE bus
61	R	*	60 TIE bus
62	R	*	104 AMTIE
63	R	*	110 Port Status
64	R	*	114 Read data
65	R	*	240 CAS status
66	R	*	241 CBUS status
67	R	*	300 DBUS status
70	R	*	320 WMC status
71	R	*	321 TU select 0
72	R	*	322 TU select 1
73	R	*	323 Write data
74	R	*	324 Byte counter <7:0>
75	R	*	324 Byte counter <15:8>
76	R	*	325 Pad counter <7:0>
77	R	*	325 Pad Counter <15:8>
100	R	*	326 Ecode counter <7:0>
101	R	*	326 Ecode counter <15:8>
102	R	*	330 DDR/MBD A.
103	R	*	331 DDR/MBD B.
104	R	*	332 WMC Errors
105	R	*	340 Interrupt status
106	R	*	0 MIA status
107	R	*	1 MIA status A
110	R	*	3 MIA status B
111	R	*	4 Serial NR A
112	R	*	4 Serial NR B
113	R	*	5 TU diagnostics
114	R	*	Retry counter
<p>This item count of number of retry requests given. A zero means tape unit is not in error recovery.</p>			
115	R	*	Retry control bits

Table 2-7 Maintenance Instruction Codes (Cont)

Instruction Code	Description	Controlling Parameter Items (Table 2-6)
C. In-Line Diagnostic Control Instructions		
16	Run in-line diagnostic (Table 2-2)	1,10,15
32	Run tape speed adjustment routine	1
34	Run start ramp adjustment routine	1
36	Run forward stop ramp adjustment routine	1
40	Run reverse stop ramp adjustment routine	1
42	Write 13 mm (0.5 in) record pattern generator - PE	1,3,12,147
44	Write 13 mm (0.5 in) record using pattern generator - GCR	1,3,12,147
D. Privileged Instructions (TM78 must be off-line)		
26	Write continuously at 3200 FRPI in all tracks	0,12
30	Write continuously at 9042 FRPI in all tracks	0,12
46	Write continuously using pattern generator - PE	0,3,12,147
50	Write continuously using pattern generator - GCR	0,3,12,147

Table 2-7 Maintenance Instruction Codes (Cont)

Instruction Code	Description	Controlling Parameter Items (Table 2-6)
61	Write data — PE	0,1,11,12,16,20
63	Write data — GCR	0,1,11,12,16,20
71	Read forward	0,1,11,13,14,17,21
77	Read reverse	0,1,11,13,14,17,21
B. Program Control Instructions (Do Not Use with EXE/REP Keys)		
0	NO—OP	1
2	Halt	7
4	Increment counter +1	1,3
6	Decrement counter +1	1,3
10	Update parameter items 26 through 157 with current hardware status	0,1
12	Display contents of counter.	1,3
14	Display contents of parameter item addressed by counter.	1,3
100 + n	Load counter with n (n = 0–77)	1,3
200 + x	Branch if error status	1,4
220 + x	Branch if no error status	1,4
240 + x	Branch if EOT detected	1,4
260 + x	Branch if no EOT detected	1,4
300 + x	Branch if tape mark detected	1,4
320 + x	Branch if no tape mark detected	1,4
340 + x	Branch if counter not zero	1,3
360 + x	Unconditional branch	1

x = Item number (0 to 17) of next instruction if branch condition is true

Table 2-6 Parameter Items (Cont)

Item Number	Read/Write	Initialized Value	Description
			Bit 5 – initial command moved tape in reverse
			Bit 6 – initial command was a read
			Bit 7 – last retry requested was in opposite direction of initial command
116	R	*	TU software status
			Bit 0 – DSE command in progress
			Bit 1 – rewinding command in progress
			Bit 2 – tape unit exists
			Bit 3 – motion command (NDT) in progress
			Bit 4 – moved in reverse direction last
			Bit 5 – last operation wrote on tape
			Bit 6 – last record seen was tape mark
			Bit 7 – Massbus port B issued last command
117	R	*	Transfer control word
			This item is the control word for last data transfer command
			Bits 0–2 – write clock select
			Bits 3–5 – read clock select
			Bits 6 – PLO bypass
			Bit 7 – low read threshold
120	R	*	Retry suppress and format control

*Item value is not initialized by enabling keypad.

Table 2-6 Parameter Items (Cont)

Item Number	Read/Write	Initialized Value	Description
			This item is a copy of Massbus register containing retry suppress, format and skip count.
121	R	*	Keypad enable flag This item is nonzero when keypad is enabled.
122 – 137			Not used
140	R	*	MIA register 0, TU78 status
140	W	*	MIA register 0, TU CMD A
141	R	*	MIA register 1, MIA status a
141	W	*	MIA register 1, TU CMD B
142	R	*	MIA register 2, MIA status b
142	W	*	MIA register 2, AMTIE loop
143	R	*	MIA register 3, serial No. a
143	W	*	MIA register 3, threshold
144	R	*	MIA register 4, serial No. B
144	W		Not used
145	R	*	MIA register 5, TU diagnostics
145	W		Not used
146	–		Not used
147	R/W	*	MIA register 7, pattern generator data
150 – 157			Not used
			Items 140 – 147 are explained in Appendix C of the Technical Manuals.

*Item value is not initialized by enabling keypad.

2.7.4 Maintenance Instructions

A table of 16 maintenance instructions may be assembled and run using the **INS**, **STA** and **CON** keys. Single instructions may also be executed with the **EXE** and **REP** keys. The transport being exercised must be selected to port #3. Table 2-7 lists all available maintenance instruction codes, their description, and the parameter item codes that influence the execution of that instruction. Tape Command (Group A), Program Control (Group B), and In-Line diagnostic control instructions (Group C) may all be run while the TM78 is off-line or on-line with the host CPU using another transport. However, privileged instructions (Group D) require that both ports of the TM78 be placed off-line.

Table 2-7 Maintenance Instruction Codes

Instruction Code	Description	Controlling Parameter Items (Table 2-6)
A. Tape Commands (Nonprivileged)		
5	Rewind and unload tape	0,1
7	Rewind tape	0,1
15	Write tape mark – PE	0,1,12
17	Write tape mark – GCR	0,1,12
21	Space one record forward	0,1,13,14
23	Space one record reverse	0,1,13,14
31	Space forward one record or file	0,1,13,14
33	Space reverse one record or file	0,1,13,14
35	Erase extended gap – PE	0,1
37	Erase extended gap – GCR	0,1
51	Loop write-to-read at TU port – PE	0,1,15
53	Loop write-to-read at TU port – GCR	0,1,15
55	Loop write-to-read at MIA	0,1,15
57	Loop write-to-read at MIA PCBA – GCR	0,1,15

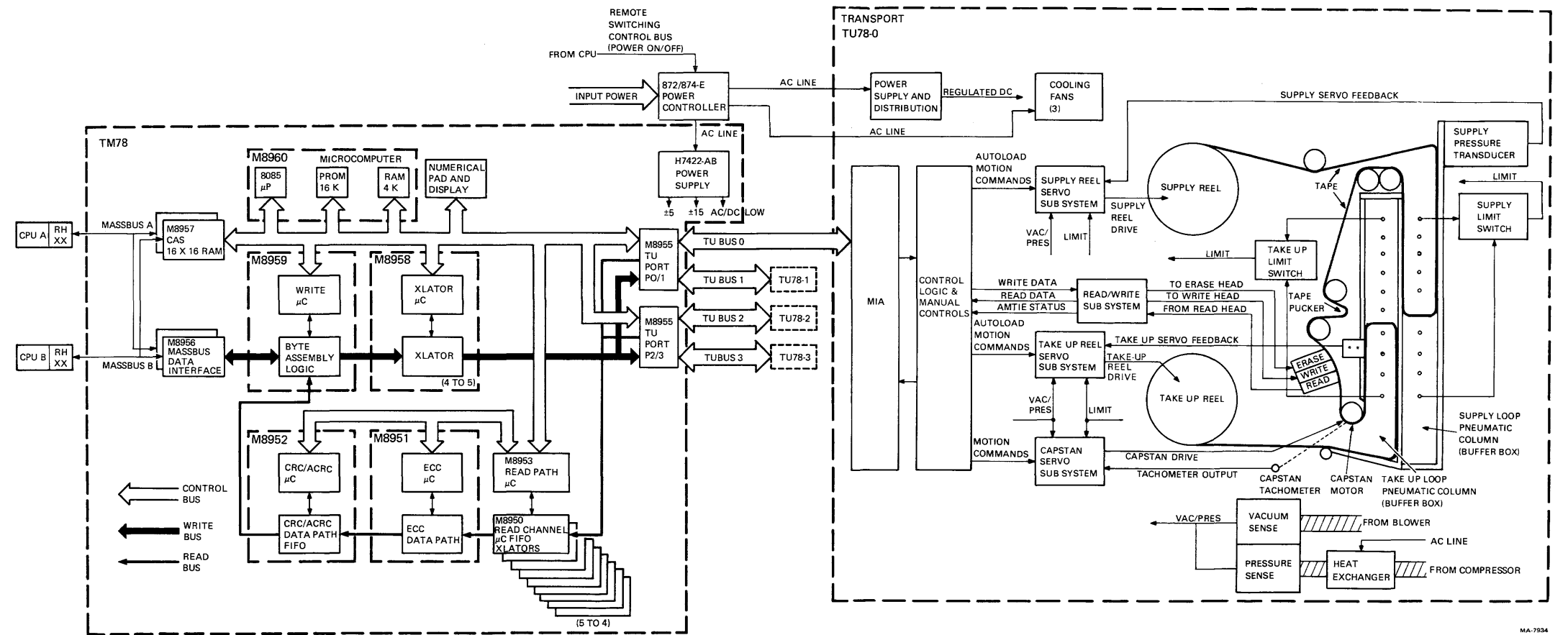

TU78 Subsystem Detailed Block Diagram

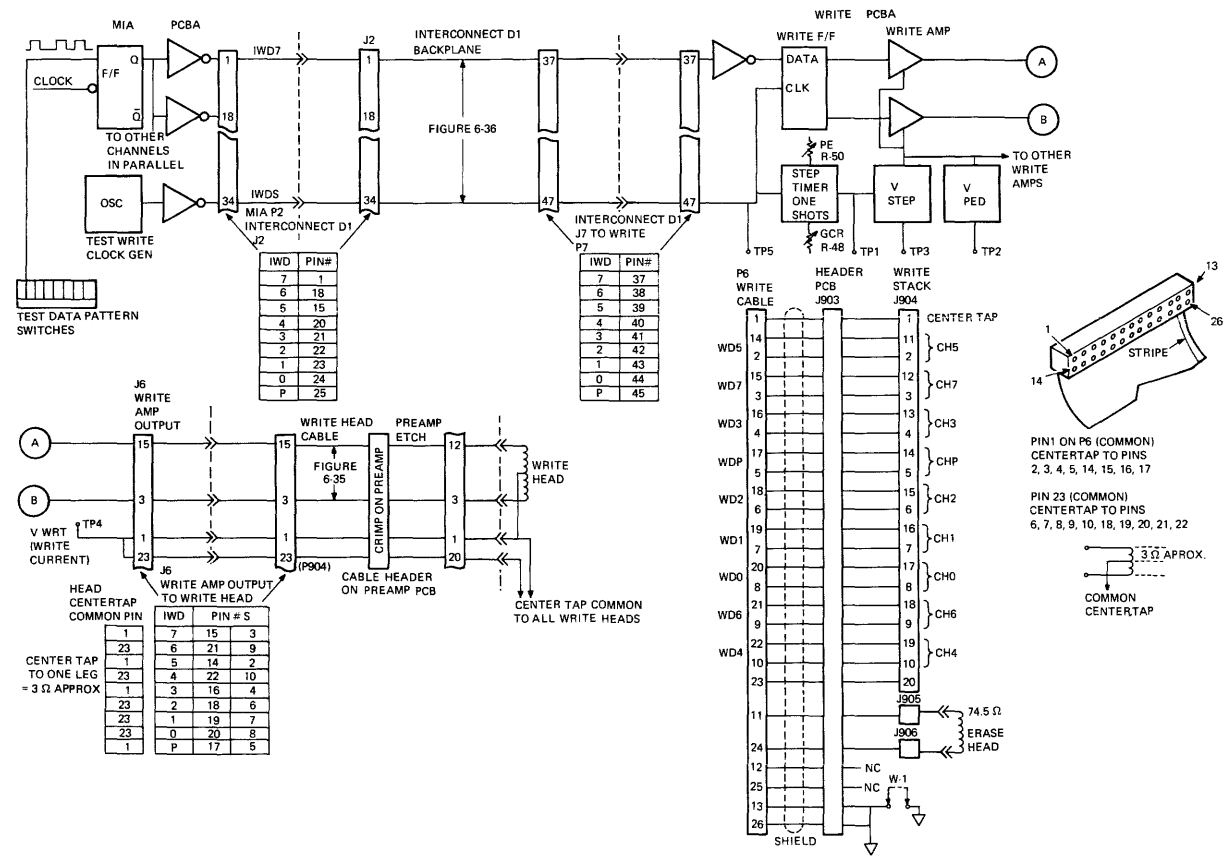

Write Path Troubleshooting Diagram

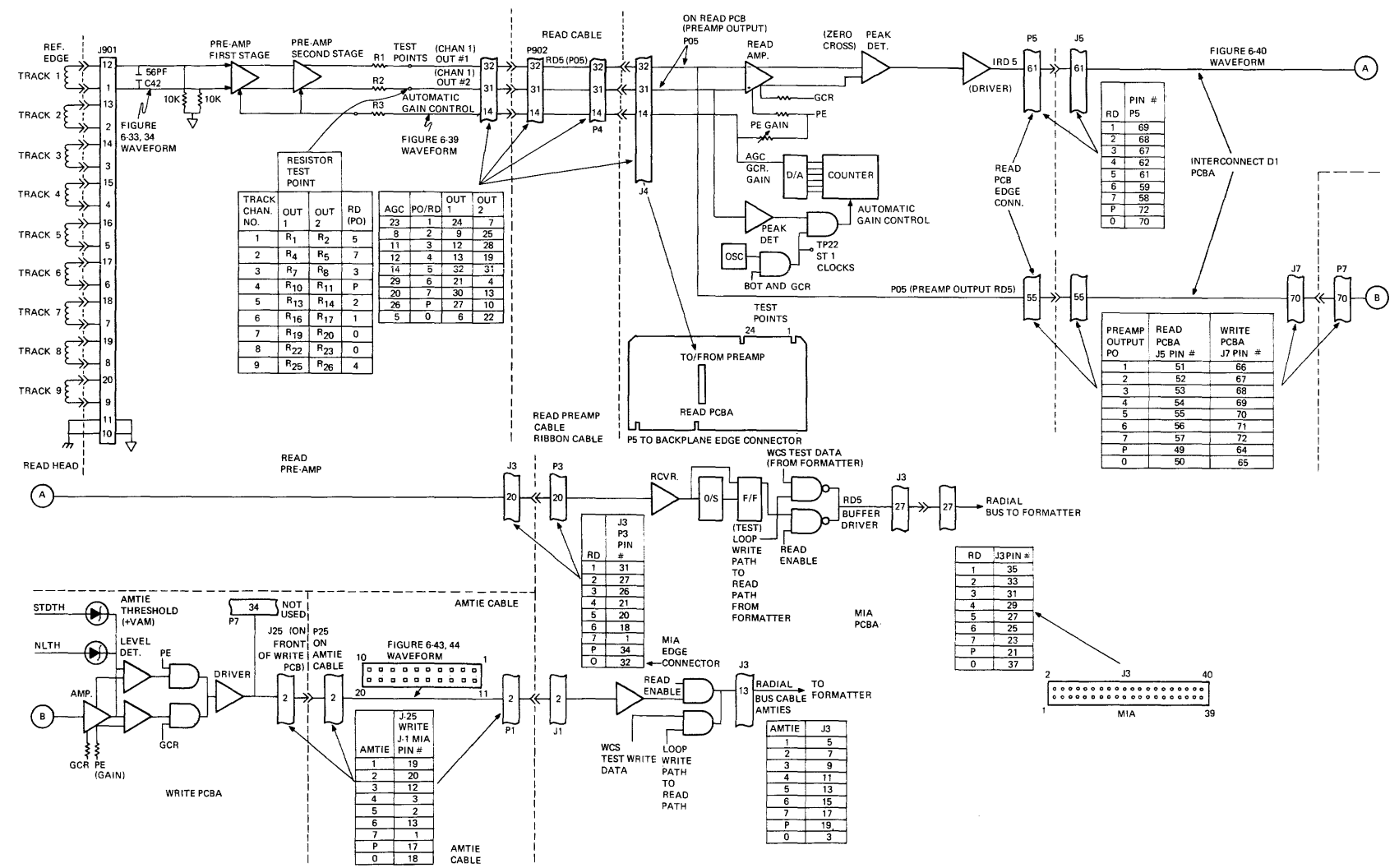

Read Path Troubleshooting Diagram